

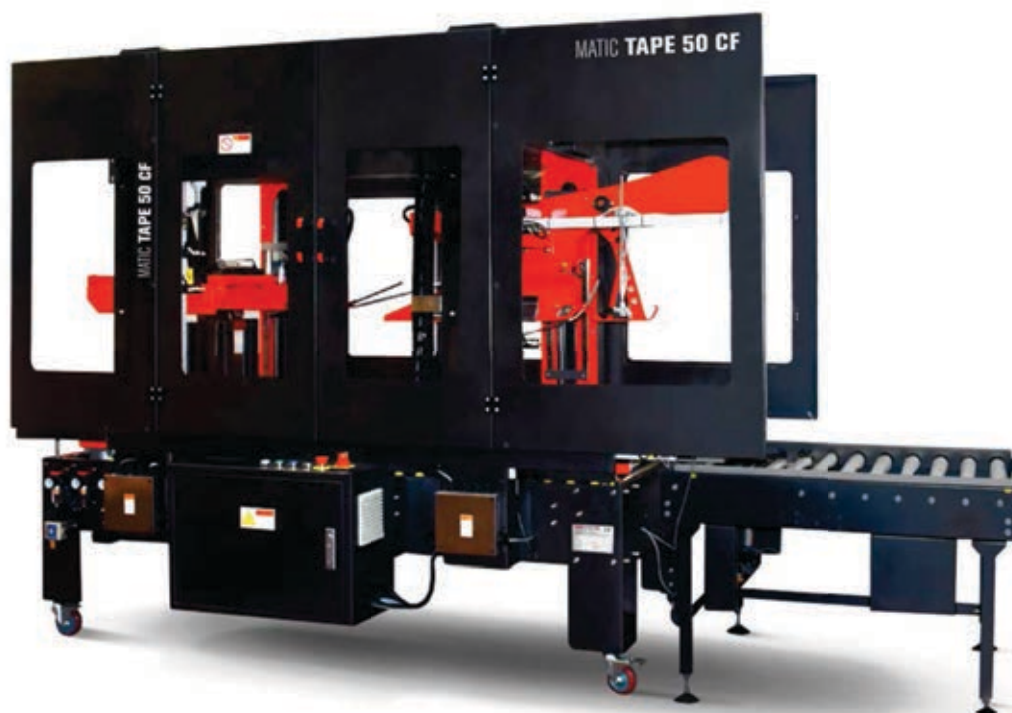

ISG>PACK
AUTOMATIC PACKAGING SYSTEM

Nastratrici per scatole

CARTON SEALERS



ECO TAPE 50 SB

 220 VOLTS



Nastratrice semiautomatica "entry level" a dimensionamento manuale, che sigilla con nastro autoadesivo la parte inferiore e superiore di scatole a formato fisso di tipo americano. Munita di sistema "Energy Saving" con arresto temporizzato del trascinamento a nastratura ultimata. La macchina può essere utilizzata da operatori non specializzati poiché richiede semplicissime operazioni di regolazione. L'avanzamento della scatola avviene mediante due cinghie laterali comandate da due motori, garantendo così la massima uniformità di scorrimento. Il risultato è un perfetto allineamento delle falde e quindi una sigillatura ottimale, che viene effettuata dalle performanti teste nastranti. Corredata di rulliere in ingresso ed uscita, sistema di risparmio energetico e ruote. Teste di nastratura fisse non amovibili dalla macchina.



Semi-automatic "entry level" manual dimensioning carton sealer which seals the top and the bottom of American type fixed size boxes with adhesive tape. The carton sealer is equipped with an "Energy Saving" timing stop system when taping and sealing operation finishes. The machine can be used by non-specialized operator thanks to easy adjusting operations. Box feeding is regulated by two lateral belts controlled by two motors and this system ensures the maximum sliding uniformity. The result is a perfect alignment of the box flaps and optimum sealing, performed by the efficient taping head. Machine is equipped with infeed and outfeed rollers, energy saving system and wheels. Fixed taping heads no removable from machine.



Macchine con dimensioni a richiesta
Customized machines on request



Presenza dell'operatore
With operator

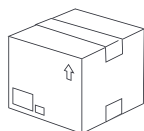

Nastratura superiore/inferiore
Top/bottom sealing

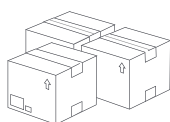

Cartoni monofornato
Uniform carton



Disponibile in acciaio Inox
Stainless steel version

ECO TAPE 50 SB SS



SISTEMA DI RISPARMIO ENERGETICO
ENERGY SAVING SYSTEM



PARTICOLARE TESTA NASTRANTE INFERIORE
DETAIL OF BOTTOM TAPING HEAD



RULLIERIA INGRESSO/USCITA DI SERIE
INFEED/OUTFEED ROLLERS INCLUDED



VERSIONE ACCIAIO INOX
STAINLESS STEEL VERSION

Caratteristiche tecniche

- ⊕ Peso: 120 Kg
- ⊕ Alimentazione elettrica: 220 Volts - 50 / 60 Hz
- ⊕ Velocità di trasferimento scatola: 22 mt / min
- ⊕ Peso max scatola: 20 Kg
- ⊕ Dimensioni macchina: L 1430 x W 960 x H 1460 -1580 mm
- ⊕ Rumorosità max: ≤ 75 db
- ⊕ Fungo di emergenza per le normative CE
- ⊕ Nastro adesivo: Kraft, Polipropilene, PVC
- ⊕ Teste nastranti standard: 50 - 60 mm
- ⊕ Altezza piano lavoro: 650 - 770 mm

Technical details

- ⊕ Weight: 120 kg
- ⊕ Power supply: 220 Volts - 50 / 60 Hz
- ⊕ Box transfer speed: 22 mt / min
- ⊕ Maximum box weight: 20 kg
- ⊕ Machine dimensions: L 1430 x W 960 x H 1460 -1580 mm
- ⊕ Maximum Noise: ≤ 75 db
- ⊕ Emergency stop in compliance with CE regulations
- ⊕ AdhesiveTape: Kraft, Polypropylene, PVC
- ⊕ Standard taping heads: 50 - 60 mm
- ⊕ Working table height: 650 - 770 mm

	DIMENSIONI SCATOLE BOX DIMENSION	
	MINIMO MIN	MASSIMO MAX
LUNGHEZZA LENGTH	150 mm	∞
LARGHEZZA WIDTH	120 mm	500 mm
ALTEZZA HEIGHT	110 mm	500 mm

	NASTRO ADESIVO ADHESIVE TAPE	
	TIPO TYPE	MASSIMO MAX
50 mm	PP PVC KRAFT	990 mt
60 mm	PP PVC KRAFT	990 mt
-	-	-

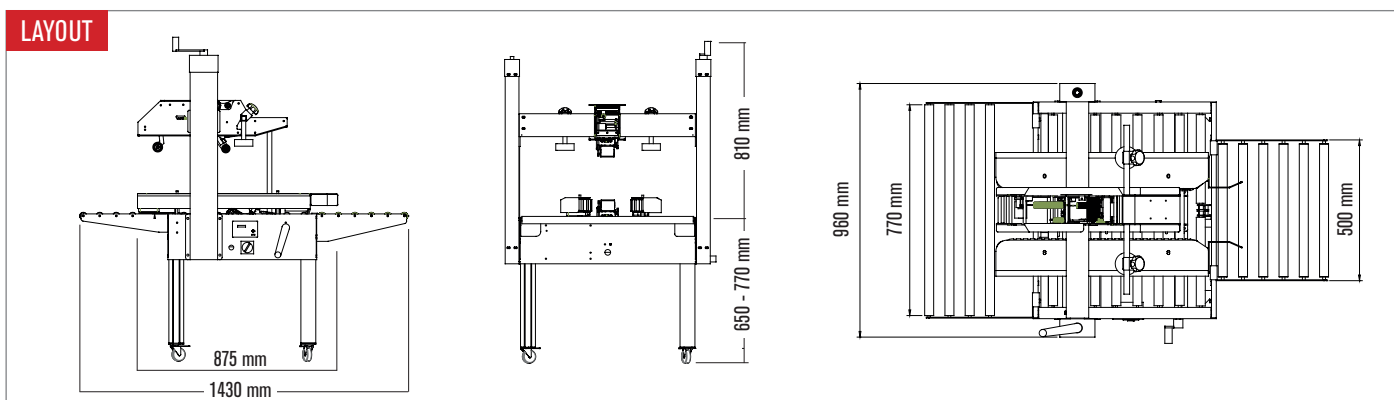

DATI TECNICI | DATA SHEET

Alimentazione elettrica | Power supply

ECO TAPE 50 SB

220 volts - 1 ph - 50 / 60 Hz

Potenza Installata | Installed power

0,24 kW

Pressione aria | Air pressure

-

Consumo aria | Air consumption

-

Velocità nastratura | Sealing speed

Fino a 15 scatole min | Up to 15 boxes min

Testa nastrante | Taping head

50 - 60 mm

CARATTERISTICHE PRODOTTO LAVORABILE | PRODUCT FEATURES

Dimensioni min. scatole | Min box dimension

L 150 x W 120 x H 110 mm

Dimensioni max scatole | Max box dimension

L ∞ x W 500 x H 500 mm

Tipologia di scatole | Box type

scatole di tipo americano | American type boxes

MINI TAPE 50 SB

 220 VOLTS



Nastratrice semiautomatica a dimensionamento manuale, che sigilla con nastro autoadesivo la parte inferiore e superiore di scatole a formato fisso di tipo americano. La macchina può essere utilizzata da operatori non specializzati poiché richiede semplicissime operazioni di regolazione. Nasce per la nastratura di scatole di piccole dimensioni con un minimo di 95 mm di altezza e 70 mm di larghezza. L'avanzamento della scatola avviene mediante due cinghie laterali comandate da due motori, garantendo così la massima uniformità di scorrimento. Il risultato è un perfetto allineamento delle falde e quindi una sigillatura ottimale, che viene effettuata dalle performanti teste nastranti. Corredata di rulliere in ingresso ed in uscita, lama ferma scatole e ruote costituendo una semplice e pratica postazione di imballaggio.



Semi-automatic manual dimensioning carton sealer which seals the top and the bottom of American type fixed size boxes with adhesive tape. The machine can be used by non-specialized operator thanks to easy adjusting operations. Conceived for taping small boxes with a minimum height and width of 70 mm and 95 mm respectively. Box feeding is regulated by two lateral belts controlled by two motors and this system ensures maximum sliding uniformity. The result is a perfect alignment of the box flaps and optimum sealing, performed by the efficient taping head. Machine is equipped with infeed and outfeed rollers, blade to stop the box and wheels represents a practical and simple packaging station.



Macchine con dimensioni a richiesta
Customized machines on request



Presenza dell'operatore
With operator

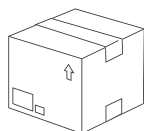

Nastratura superiore/inferiore
Top/bottom sealing

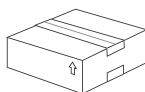

Cartoni piccoli
Small cartons



Disponibile in acciaio Inox
Stainless steel version

MINI TAPE 50 SB SS



INTERRUTTORE GENERALE
MAIN POWER SWITCH



PARTICOLARE TESTA NASTRANTE INFERIORE
DETAIL OF BOTTOM TAPING HEAD



RULLIERIA INGRESSO/USCITA DI SERIE
INFEED/OUTFEED ROLLERS INCLUDED



REGOLAZIONE LARGHEZZA SCATOLA
BOX WIDTH ADJUSTMENT

Caratteristiche tecniche

- ⊕ Peso: 190 Kg
- ⊕ Alimentazione elettrica: 220 Volt - 50 / 60 Hz
- ⊕ Velocità di trasferimento scatola: 19 mt / min
- ⊕ Peso max scatola: 30 Kg
- ⊕ Dimensioni macchina: L 1980 × W 710 x H 1360 -1560 mm
- ⊕ Rumorosità max: ≤ 75 db
- ⊕ Fungo di emergenza per le normative CE
- ⊕ Nastro adesivo: Kraft, Polipropilene, PVC
- ⊕ Testa nastrante standard: 50 mm
- ⊕ Altezza piano lavoro: 600 - 800 mm

Technical details

- ⊕ Weight: 190 kg
- ⊕ Power supply: 220 Volt - 50 / 60 Hz
- ⊕ Box transfer speed: 19 mt / min
- ⊕ Maximum box weight: 30 kg
- ⊕ Machine dimensions: L 1980 × W 710 x H 1360 -1560 mm
- ⊕ Maximum Noise: ≤ 75 db
- ⊕ Emergency stop in compliance with CE regulations
- ⊕ Adhesive tape: Kraft, Polypropylene, PVC
- ⊕ Standard taping head : 50 mm
- ⊕ Working table height: 600 - 800 mm

	DIMENSIONI SCATOLE BOX DIMENSION	
	MINIMO MIN	MASSIMO MAX
LUNGHEZZA LENGTH	200 mm	∞
LARGHEZZA WIDTH	95 mm	300 mm
ALTEZZA HEIGHT	70 mm	500 mm

	NASTRO ADESIVO ADHESIVE TAPE	
	TIPO TYPE	MASSIMO MAX
50 mm	PP PVC KRAFT	990 mt
-	-	-
-	-	-

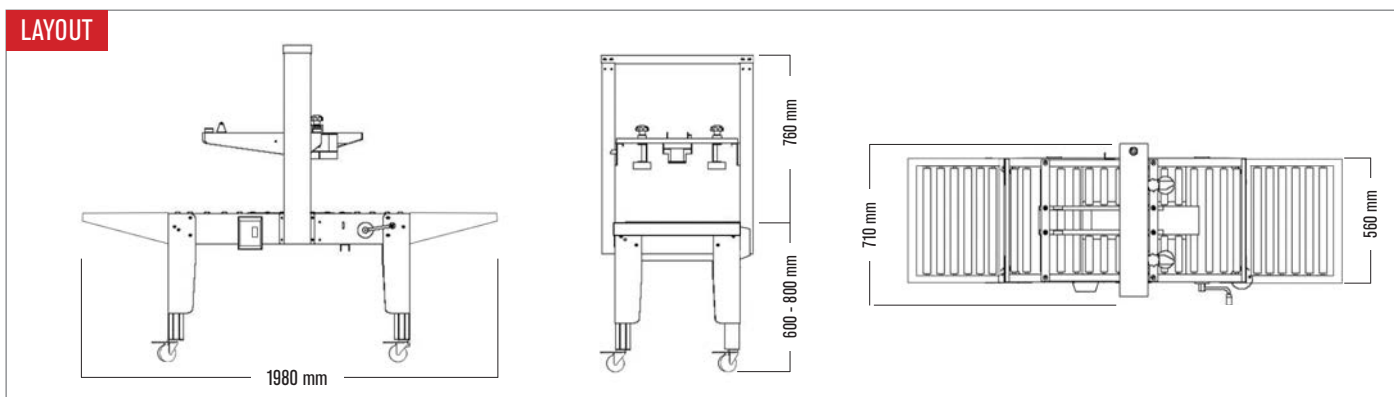

DATI TECNICI | DATA SHEET

Alimentazione elettrica Power supply	220 volts - 1 ph - 50 / 60 Hz
Potenza Installata Installed power	0,40 kW
Pressione aria Air pressure	-
Consumo aria Air consumption	-
Velocità nastratura Sealing speed	Fino a 15 scatole min Up to 15 boxes min
Testa nastrante Taping head	50 mm

CARATTERISTICHE PRODOTTO LAVORABILE | PRODUCT FEATURES

Dimensioni min scatole Min box dimension	L 200 x W 95 x H 70 mm
Dimensioni max scatole Max box dimension	L ∞ x W 300 x H 500 mm
Tipologia di scatole Box type	Scatole di tipo americano American type boxes

EASY TAPE 50 SB

 220 VOLTS



Nastratrice semiautomatica a dimensionamento manuale, versione accessoriata che sigilla con nastro autoadesivo la parte inferiore e superiore di scatole a formato fisso di tipo americano. Munita di sistema "Energy Saving" con arresto temporizzato del trascinamento a nastratura ultimata. Dotata di un sistema chiudi tre falde per facilitare l'operazione di chiusura scatola, può essere utilizzata da operatori non specializzati poiché richiede semplicissime operazioni di regolazione. L'avanzamento della scatola avviene mediante due cinghie laterali comandate da due motori, garantendo così la massima uniformità di scorrimento. Il risultato è un perfetto allineamento delle falde e quindi una sigillatura ottimale, che viene effettuata dalle performanti teste nastranti. Corredata di rulliere in ingresso ed uscita, sistema di risparmio energetico, lama ferma scatole, sistema chiudi tre-falde e ruote, costituendo una semplice e pratica postazione di imballaggio.



Semi-automatic manual dimensioning carton sealer, which seals the top and the bottom of American-type fixed size boxes, with adhesive tape. The carton sealer is equipped with an "Energy Saving" timing stop system when box taping and sealing operation finishes. The machine is equipped with a 3 flaps closing system to facilitate the box closure and can be used by non-specialized operators because it requires easy adjustments. Box feeding is regulated by two lateral belts controlled by two motors, this system ensures the maximum sliding uniformity. The result is a perfect alignment of the box flaps and optimum sealing, performed by the efficient taping head. Machine is equipped with infeed and outfeed rollers, energy saving system, blade to stop the box, 3 flap closure system and wheels, represents a practical and simple packaging station.



Macchine con dimensioni a richiesta
Customized machines on request



Presenza dell'operatore
With operator

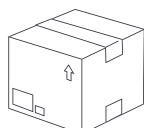

Nastratura superiore/inferiore
Top/bottom sealing

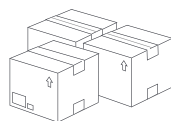

Cartoni monoformato
Uniform carton



Disponibile in acciaio Inox
Stainless steel version

EASY TAPE 50 SB SS



SISTEMA DI RISPARMIO ENERGETICO
ENERGY SAVING SYSTEM



TESTA DI NASTRATURA
TAPING HEAD



RULLIERIA INGRESSO/USCITA DI SERIE
INFEED/OUTFEED ROLLERS INCLUDED



VERSIONE ACCIAIO INOX
STAINLESS STEEL VERSION

Caratteristiche tecniche

- ⊕ Peso: 250 Kg
- ⊕ Alimentazione elettrica: 220 Volts - 50 / 60 Hz
- ⊕ Velocità di trasferimento scatola: 20 mt / min
- ⊕ Peso max scatola: 30 Kg
- ⊕ Dimensioni macchina: L 1940 x W 900 x H 1410 - 1510 mm
- ⊕ Rumorosità max: ≤ 75 db
- ⊕ Fungo di emergenza per le normative CE
- ⊕ Nastro adesivo: Kraft, Polipropilene, pvc
- ⊕ Testa nastrante standard: 50 - 75 mm
- ⊕ Altezza piano lavoro: 650 - 750 mm

Technical details

- ⊕ Weight: 250 kg
- ⊕ Power supply: 220 Volts - 50 / 60 Hz
- ⊕ Box transfer speed: 20 mt / min
- ⊕ Maximum box weight: 30 kg
- ⊕ Machine dimensions: L 1940 x W 900 x H 1410 - 1510 mm
- ⊕ Maximum Noise: ≤ 75 db
- ⊕ Emergency stop in compliance with CE regulations
- ⊕ Adhesive tape: Kraft, Polypropylene, PVC
- ⊕ Standard taping head: 50 - 75 mm
- ⊕ Working table height: 650 - 750 mm

	DIMENSIONI SCATOLE BOX DIMENSION	
	MINIMO MIN	MASSIMO MAX
LUNGHEZZA LENGTH	150 mm	∞
LARGHEZZA WIDTH	150 mm	500 mm
ALTEZZA HEIGHT	110 mm	500 mm

	NASTRO ADESIVO ADHESIVE TAPE	
	TIPO TYPE	MASSIMO MAX
50 mm	PP PVC KRAFT	990 mt
75 mm	PP PVC KRAFT	990 mt
-	-	-

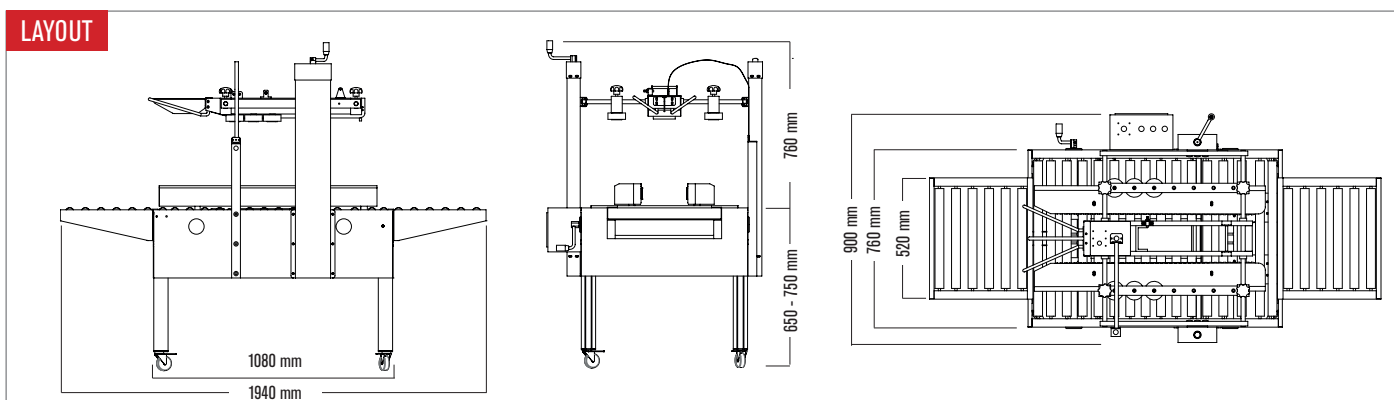

DATI TECNICI | DATA SHEET

Alimentazione elettrica | Power supply

Potenza Installata | Installed power

Pressione aria | Air pressure

Consumo aria | Air consumption

Velocità nastratura | Sealing speed

Testa nastrante | Taping head

EASY TAPE 50 SB

220 volts - 1 ph - 50 / 60 Hz

0,40 kW

-

-

Fino a 15 scatole min | Up to 15 boxes min

50 - 75 mm

CARATTERISTICHE PRODOTTO LAVORABILE | PRODUCT FEATURES

Dimensioni min. scatole | Min box dimension

Dimensioni max. scatole | Max box dimension

Tipologia di scatole | Box type

L 150 x W 150 x H 110 mm

L ∞ x W 500 x H 500 mm

Scatole di tipo americano | American type boxes

EASY TAPE 70 TSB

 220 VOLTS



Nastratrice semiautomatica a dimensionamento manuale progettata per la nastratura di scatole di grandi dimensioni, che sigilla con nastro autoadesivo la parte inferiore e superiore di scatole a formato fisso di tipo americano. L'avanzamento della scatola avviene mediante due cinghie laterali comandate da due motori e due cinghie superiori comandate da un motore, garantendo così la massima uniformità di scorrimento. Il risultato è un perfetto allineamento delle falde e quindi una sigillatura ottimale, che viene effettuata dalle performanti teste nastranti. Corredata di rulliere in ingresso ed uscita, lama ferma scatole e ruote costituendo una semplice e pratica postazione di imballaggio.



Semi-automatic manual adjustment carton conceived for taping big boxes, which seals the top and the bottom of Americantype fixed size boxes, with adhesive tape. Box feeding is regulated by two lateral belts controlled by two motors and by two top belts controlled by a motor. This system ensures the maximum sliding uniformity. The result is a perfect alignment of the flaps and optimum sealing, performed by the efficient taping heads. Machine is equipped with infeed and outfeed rollers, blade to stop the box and wheels represents a practical and simple packaging station.

 **Macchine con dimensioni a richiesta**
Customized machines on request

 **Presenza dell'operatore**
With operator

 **Nastratura superiore/inferiore**
Top/bottom sealing

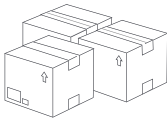
 **Cartoni monofornato**
Uniform carton

 **Disponibile in acciaio Inox**
Stainless steel version
EASY TAPE 70 TSB SS



PANNELLO DI CONTROLLO
CONTROL PANEL



TESTA DI NASTRATURA
TAPING HEAD



CINGHIE SUPERIORI MOTORIZZATE
TWO TOP BELT CONTROLLED BY A MOTOR



RUOTE DI SERIE
WHEELS INCLUDED

Caratteristiche tecniche

- ⊕ Peso: 180 Kg
- ⊕ Alimentazione elettrica: 220 Volts - 50 / 60 Hz
- ⊕ Velocità di trasferimento scatola: 20 mt / min
- ⊕ Peso max scatola: 30 Kg
- ⊕ Dimensioni macchina: L 2000 x W 1110 x H 1650 - 1850 mm
- ⊕ Rumorosità max: ≤ 75 db
- ⊕ Fungo di emergenza per le normative CE
- ⊕ Nastro adesivo: Kraft, Polipropilene, PVC
- ⊕ Testa nastrante standard: 50 - 75 mm
- ⊕ Altezza piano lavoro: 600 - 800 mm

Technical details

- ⊕ Weight: 180 kg
- ⊕ Power supply: 220 Volts - 50 / 60 Hz
- ⊕ Box transfer speed: 20 mt / min
- ⊕ Maximum box weight: 30 kg
- ⊕ Machine dimensions: L 2000 x W 1110 x H 1650 - 1850 mm
- ⊕ Maximum Noise: ≤ 75 db
- ⊕ Emergency stop in compliance with CE regulations
- ⊕ Adhesive tape: Kraft, Polypropylene, PVC
- ⊕ Standard taping head: 50 - 75 mm
- ⊕ Working table height: 600 - 800 mm

	DIMENSIONI SCATOLE BOX DIMENSION	
	MINIMO MIN	MASSIMO MAX
LUNGHEZZA LENGTH	150 mm	∞
LARGHEZZA WIDTH	120 mm	700 mm
ALTEZZA HEIGHT	130 mm	700 mm

	NASTRO ADESIVO ADHESIVE TAPE	
	TIPO TYPE	MASSIMO MAX
50 mm	PP PVC KRAFT	990 mt
75 mm	PP PVC KRAFT	990 mt
-	-	-

LAYOUT

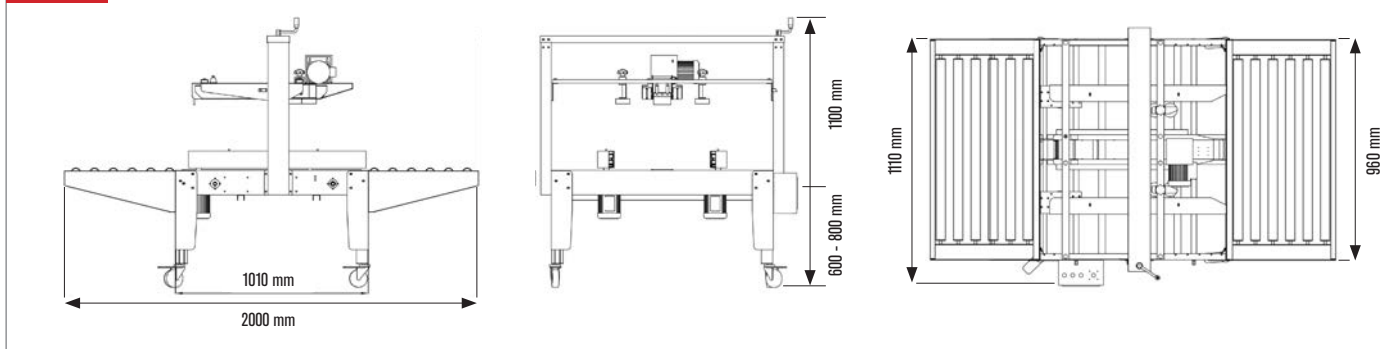

DATI TECNICI | DATA SHEET

Alimentazione elettrica | Power supply

Potenza Installata | Installed power

Pressione aria | Air pressure

Consumo aria | Air consumption

Velocità nastratura | Sealing speed

Testa nastrante | Taping head

EASY TAPE 70 TSB

220 volts - 1 ph - 50 / 60 Hz

0,60 kW

-

-

Fino a 15 scatole min | Up to 15 boxes min

50 - 75 mm

CARATTERISTICHE PRODOTTO LAVORABILE | PRODUCT FEATURES

Dimensioni min. scatole | Min box dimension

Dimensioni max. scatole | Max box dimension

Tipologia di scatole | Box type

L 150 x W 120 x H 130 mm

L ∞ x W 700 x H 700 mm

Scatole di tipo americano | American type boxes

ECO TAPE 50 TBB

 220 VOLTS



Nastratrice semiautomatica “entry level” a dimensionamento manuale, che sigilla con nastro autoadesivo la parte inferiore e superiore di scatole a formato fisso di tipo americano. Munita di sistema “Energy Saving” con arresto temporizzato del trascinamento a nastratura ultimata. La macchina può essere utilizzata da operatori non specializzati poiché richiede semplicissime operazioni di regolazione. L'avanzamento della scatola avviene mediante due cinghie di trascinamento motorizzate superiori ed inferiori, garantendo così la massima uniformità di scorrimento. Il risultato è un perfetto allineamento delle falde e quindi una sigillatura ottimale, che viene effettuata dalle performanti teste nastranti. Corredata di rulliere in ingresso ed uscita, sistema di risparmio energetico e ruote, costituendo una semplice e pratica postazione di imballaggio.



Semi-automatic “entry level” manual dimensioning carton sealer which seals the top and the bottom of American type fixed size boxes with adhesive tape. The carton sealer is equipped with an “Energy Saving” timing stop system when taping and sealing operation finishes. The machine can be used by non-specialized operator thanks to easy adjusting operations. Box feeding is regulated by 4 belts, two top and two lower. This system ensures the maximum sliding uniformity. The result is a perfect alignment of the box flaps and optimum sealing, performed by the efficient taping head. Machine is equipped with infeed and outfeed rollers, energy saving system and wheels, represents a practical and simple packaging station.



Macchine con dimensioni a richiesta
Customized machines on request



Presenza dell'operatore
With operator

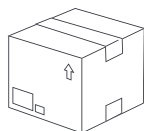

Nastratura superiore/inferiore
Top/bottom sealing

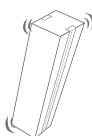

Cartoni instabili
Unstable cartons



Disponibile in acciaio Inox
Stainless steel version

ECO TAPE 50 TBB SS



SISTEMA DI RISPARMIO ENERGETICO
ENERGY SAVING SYSTEM



SISTEMA PER LA CENTRATURA DELLA SCATOLA
SYSTEM FOR CENTERING THE BOX



NASTRIS TRASPORTATORI SUPERIORI
TWO TOP BELTS



REGISTRI PER ALLINEAMENTO FALDE
ROLLER FOR FLAP ALIGNMENT

Caratteristiche tecniche

- ⊕ Peso: 120 Kg
- ⊕ Alimentazione elettrica: 220 Volts - 50 / 60 Hz
- ⊕ Velocità di trasferimento scatola: 20 mt / min
- ⊕ Peso max scatola: 30 Kg
- ⊕ Dimensioni macchina: L 1610 x W 760 x H 1340 - 1490 mm
- ⊕ Rumorosità max: ≤ 75 db
- ⊕ Fungo di emergenza per le normative CE
- ⊕ Nastro adesivo: Kraft, Polipropilene, PVC
- ⊕ Teste nastranti standard: 50 - 75 mm
- ⊕ Altezza piano lavoro: 600 - 750 mm

Technical details

- ⊕ Weight: 120 kg
- ⊕ Power supply: 220 Volts - 50 / 60 Hz
- ⊕ Box transfer speed: 20 mt / min
- ⊕ Maximum box weight: 30 kg
- ⊕ Machine dimensions: L 1610 x W 760 x H 1340 - 1490 mm
- ⊕ Maximum Noise: ≤ 75 db
- ⊕ Emergency stop in compliance with CE regulations
- ⊕ Adhesive Tape: Kraft, Polypropylene, PVC
- ⊕ Standard taping heads: 50 - 75 mm
- ⊕ Working table height: 600 - 750 mm

	DIMENSIONI SCATOLE BOX DIMENSION	
	MINIMO MIN	MASSIMO MAX
LUNGHEZZA LENGTH	150 mm	∞
LARGHEZZA WIDTH	180 mm	450 mm
ALTEZZA HEIGHT	120 mm	480 mm

	NASTRO ADESIVO ADHESIVE TAPE	
	TIPO TYPE	MASSIMO MAX
50 mm	PP PVC KRAFT	990 mt
60 mm	PP PVC KRAFT	990 mt
-	-	-

LAYOUT

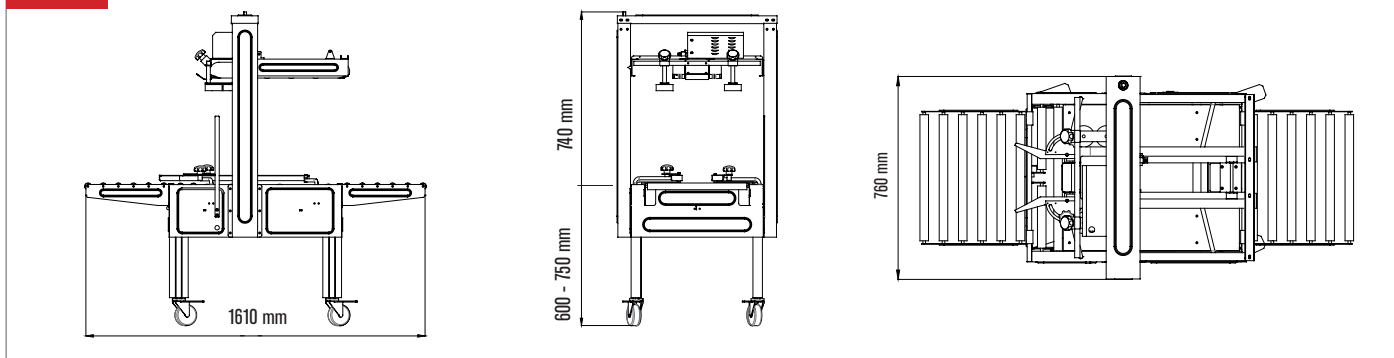

DATI TECNICI | DATA SHEET

Alimentazione elettrica | Power supply

220 volts - 1 ph - 50 / 60 Hz

Potenza Installata | Installed power

0,34 kW

Pressione aria | Air pressure

-

Consumo aria | Air consumption

-

Velocità nastratura | Sealing speed

Fino a 15 scatole min | Up to 15 boxes min

Testa nastrante | Taping head

50 - 75 mm

CARATTERISTICHE PRODOTTO LAVORABILE | PRODUCT FEATURES

Dimensioni min. scatole | Min box dimension

L 150 x W 180 x H 120 mm

Dimensioni max scatole | Max box dimension

L ∞ x W 450 x H 480 mm

Tipologia di scatole | Box type

Scatole di tipo americano | American type boxes

EASY TAPE 50 TBB

 220 VOLTS

IT

Nastratrice semiautomatica a dimensionamento manuale con quattro cinghie di trascinamento motorizzate, due inferiori e due superiori. Questa macchina è particolarmente indicata per scatole alte e corte oppure instabili. Esegue la nastratura con nastro autoadesivo della parte inferiore e superiore di scatole a formato fisso di tipo americano. Il risultato è un perfetto allineamento delle falde e quindi una sigillatura ottimale, che viene effettuata dalle performanti teste nastranti. Corredata di rulliere in ingresso ed uscita, lama ferma scatole e ruote, costituendo una semplice e pratica postazione di imballaggio.

UK

Semi-automatic manual dimensioning carton sealer with four feeding power belts, two top and bottom. The machine tapes the top and bottom of American-type fixed size boxes with adhesive tape. This carton sealer is particularly suited for tall and short or unstable boxes. The result is a perfect alignment of box flaps and optimum sealing, performed by the efficient taping head. Machine is equipped with infeed and outfeed rollers, blade to stop the box and wheels represents a practical and simple packaging station.

 **Macchine con dimensioni a richiesta**
Customized machines on request

 **Presenza dell'operatore**
With operator

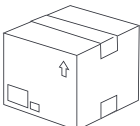
 **Nastratura superiore/inferiore**
Top/bottom sealing

 **Cartoni instabili**
Unstable cartons

 **Disponibile in acciaio Inox**
Stainless steel version
EASY TAPE 50 TBB SS



PARTICOLARE TESTA NASTRANTE
DETAIL OF THE TAPING HEAD



INTERRUTTORE GENERALE
MAIN POWER SWITCH

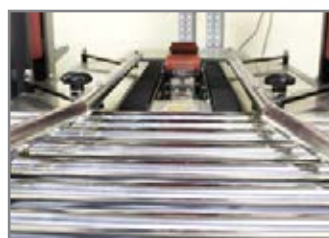

RULLIERA INGRESSO SCATOLA
INFEED ROLLER CONVEYOR



VERSIONE ACCIAIO INOX
STAINLESS STEEL VERSION

Caratteristiche tecniche

- ⊕ Peso: 100 Kg
- ⊕ Alimentazione elettrica: 220 Volts - 50 / 60 Hz
- ⊕ Velocità di trasferimento scatola: 20 mt / min
- ⊕ Peso max scatola: 30 Kg
- ⊕ Dimensioni macchina: L 1820 x W 920 x H 1490 - 1640 mm
- ⊕ Rumorosità max: ≤ 75 db
- ⊕ Fungo di emergenza per le normative CE
- ⊕ Nastro adesivo: Kraft, Polipropilene, PVC
- ⊕ Testa nastrante standard: 50 - 75 mm
- ⊕ Altezza piano lavoro: 600 - 750 mm

Technical details

- ⊕ Weight: 100 kg
- ⊕ Power supply: 220 Volts - 50 / 60 Hz
- ⊕ Box transfer speed: 20 mt / min
- ⊕ Maximum box weight: 30 kg
- ⊕ Machine dimensions: L 1820 x W 920 x H 1490 - 1640 mm
- ⊕ Maximum Noise: ≤ 75 db
- ⊕ Emergency stop in compliance with CE regulations
- ⊕ Adhesive tape: Kraft, Polypropylene, PVC
- ⊕ Standard taping head: 50 - 75 mm
- ⊕ Working table height: 600 - 750 mm

	DIMENSIONI SCATOLE BOX DIMENSION	
	MINIMO MIN	MASSIMO MAX
LUNGHEZZA LENGTH	150 mm	∞
LARGHEZZA WIDTH	150 mm	580 mm
ALTEZZA HEIGHT	120 mm	500 mm

	NASTRO ADESIVO ADHESIVE TAPE	
	TIPO TYPE	MASSIMO MAX
50 mm	PP PVC KRAFT	990 mt
75 mm	PP PVC KRAFT	990 mt
-	-	-

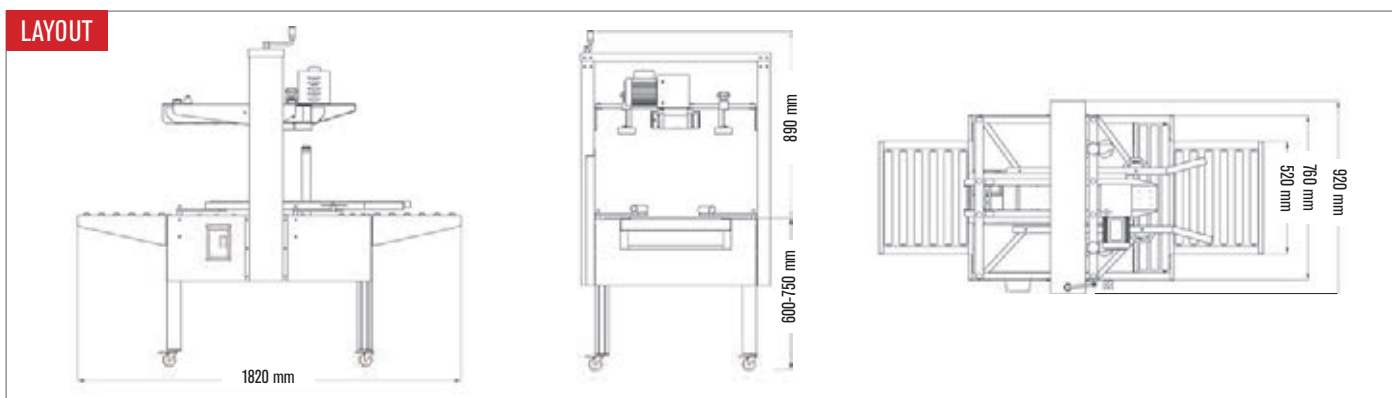

DATI TECNICI | DATA SHEET

Alimentazione elettrica | Power supply

EASY TAPE 50 TBB

220 volts - 1 ph - 50 / 60 Hz

Potenza Installata | Installed power

0,60 kW

Pressione aria | Air pressure

-

Consumo aria | Air consumption

-

Velocità nastratura | Sealing speed

Fino a 15 scatole min | Up to 15 boxes min

Testa nastrante | Taping head

50 - 75 mm

CARATTERISTICHE PRODOTTO LAVORABILE | PRODUCT FEATURES

Dimensioni min. scatole | Min box dimension

L 150 x W 150 x H 120 mm

Dimensioni max. scatole | Max box dimension

L ∞ x W 580 x H 500 mm

Tipologia di scatole | Box type

Scatole di tipo americano | American type boxes

SIDE TAPE 50 TBB

 220 VOLTS



Nastratrice semiautomatica a dimensionamento manuale con quattro cinghie di trascinamento, due inferiori e due superiori. Esegue la nastratura con nastro autoadesivo lateralmente alle scatole di formato fisso di tipo americano. Questa macchina è particolarmente indicata per chi deve confezionare in posizione orizzontale o per scatole con falde sovrapposte oppure per chiudere fondo e coperchio di scatole tipo polistirolo. Teste di nastratura regolabili in altezza in maniera indipendente. Corredata di rulliere in ingresso ed uscita e ruote, costituendo una semplice e pratica postazione di imballaggio.



Semi-automatic manual dimensioning carton sealer with four feeding power belts, two top and bottom. This machine is particularly suited for taping boxes in horizontal position, with overlapped flaps and for closing the bottom and cover of boxes like the polystyrene ones. Adjustable height of each taping head. Machine includes infeed and outfeed rollers and wheels represents a practical and simple packaging station.



Macchine con dimensioni a richiesta
Customized machines on request



Presenza dell'operatore
With operator

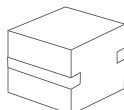

Nastratura laterale
Side sealing

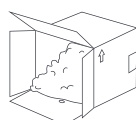

Riempimento laterale
Side filling



PANNELLO DI CONTROLLO
CONTROL PANEL



CINGHIE DI TRASCINAMENTO INFERIORI
BOTTOM BELTS FEEDING

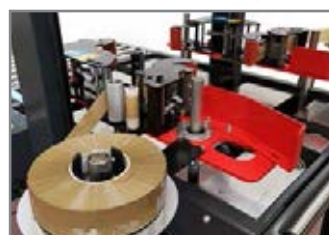

PARTICOLARE TESTA NASTRANTE
DETAIL OF THE TAPING HEAD



CINGHIE DI TRASCINAMENTO SUPERIORI
TOP FEEDING BELTS

Caratteristiche tecniche

- ⊕ Peso: 220 Kg
- ⊕ Alimentazione elettrica: 220 Volts - 50 / 60 Hz
- ⊕ Velocità di trasferimento scatola: 19 mt / min
- ⊕ **Cinghie superiori motorizzate**
- ⊕ Peso max scatola: 30 Kg
- ⊕ Dimensioni macchina: L 1840 x W 1000 x H 1250 -1500 mm
- ⊕ Rumorosità max: ≤ 75 db
- ⊕ Fungo di emergenza per le normative CE
- ⊕ Nastro adesivo: Kraft, Polipropilene, PVC
- ⊕ Testa nastrante standard: 50 - 75 mm
- ⊕ Altezza piano lavoro: 550 - 800 mm

Technical details

- ⊕ **Weight: 220 kg**
- ⊕ **Power supply: 220 Volts - 50 / 60 Hz**
- ⊕ **Box transfer speed: 19 mt / min**
- ⊕ **Power top belts**
- ⊕ **Maximum box weight: 30 kg**
- ⊕ **Machine dimensions: L 1840 x W 1000 x H 1250 - 1500 mm**
- ⊕ **Maximum Noise: ≤ 75 db**
- ⊕ **Emergency stop in compliance with CE regulations**
- ⊕ **Adhesive tape: Kraft, Polypropylene, PVC**
- ⊕ **Standard taping head: 50 - 75 mm**
- ⊕ **Working table height: 550 - 800 mm**

	DIMENSIONI SCATOLE BOX DIMENSION	
	MINIMO MIN	MASSIMO MAX
LUNGHEZZA LENGTH	150 mm	∞
LARGHEZZA WIDTH	190 mm	450 mm
ALTEZZA HEIGHT	130 mm	520 mm

	NASTRO ADESIVO ADHESIVE TAPE	
	TIPO TYPE	MASSIMO MAX
50 mm	PP PVC KRAFT	990 mt
75 mm	PP PVC KRAFT	990 mt
-	-	-

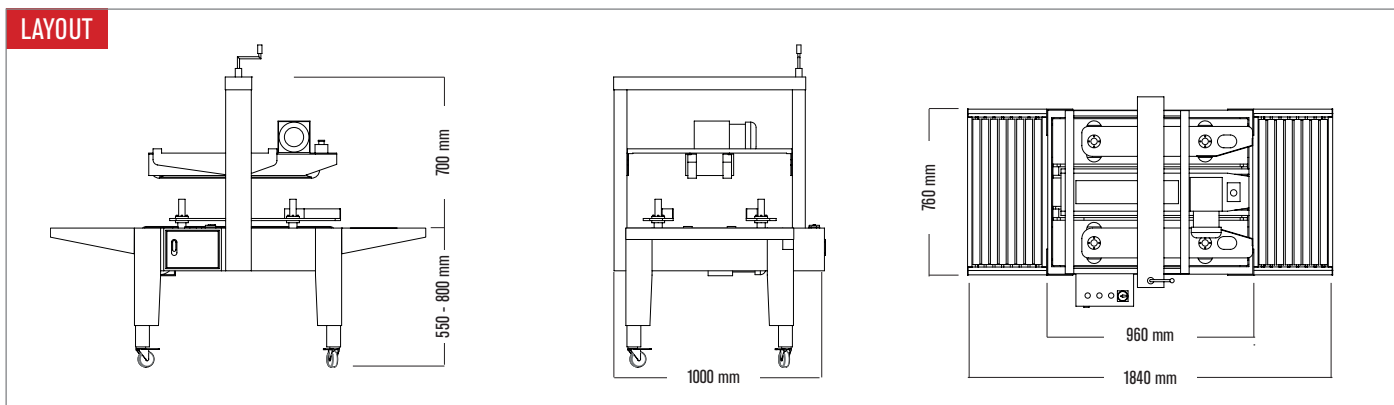

DATI TECNICI | DATA SHEET

Alimentazione elettrica | Power supply

Potenza Installata | Installed power

Pressione aria | Air pressure

Consumo aria | Air consumption

Velocità nastratura | Sealing speed

Testa nastrante | Taping head

SIDE TAPE 50 TBB

220 volts - 1 ph - 50 / 60 Hz

0,40 kW

-

-

Fino a 15 scatole min | Up to 15 boxes min

50 - 75 mm

CARATTERISTICHE PRODOTTO LAVORABILE | PRODUCT FEATURES

Dimensioni min. scatole | Min box dimension

Dimensioni max. scatole | Max box dimension

Tipologia di scatole | Box type

L 150 x W 190 x H 130 mm

L ∞ x W 450 x H 520 mm

Scatole di tipo americano | American type boxes

RANDOM TAPE 50 SB

 220 VOLTS



Nastratrice semiautomatica autodimensionante che sigilla con nastro autoadesivo la parte superiore ed inferiore delle scatole di tipo americano a formato variabile. Nel ciclo di lavoro l'operatore squadra la scatola piegandone le falde inferiori per procedere al riempimento, dopodiché chiude le falde superiori e la spinge all'interno macchina. Si attiva il dimensionamento della macchina rispetto alla misura della scatola. L'avanzamento della scatola avviene tramite due cinghie laterali, durante il passaggio in macchina la scatola viene nastrata simultaneamente sopra e sotto. Il risultato è un perfetto allineamento delle falde e quindi una sigillatura ottimale, che viene effettuata dalla performante testa nastrante. Corredata di rulliere in ingresso ed uscita, lama ferma scatole e ruote, costituendo una semplice e pratica postazione di imballaggio.



Semi-automatic and self-dimensioning carton sealer which seals the top and bottom of American-type variable size boxes with adhesive tape. The operator squares the boxes, folds the bottom flaps, fills the boxes, folds the top flaps, and then guides them into the machine where the centering/holding unit self-adjust to the box. Box feeding is regulated by two lateral belts. The top and the bottom flaps will be sealed simultaneously. The result is a perfect alignment of the flaps. Machine includes infeed and outfeed rollers and represents a practical and simple packaging station. Machine is equipped with infeed and outfeed rollers, blade to stop the box and wheels represents a practical and simple packaging station.



Macchine con dimensioni a richiesta
Customized machines on request



Presenza dell'operatore
With operator

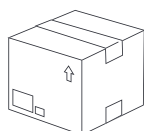

Nastratura superiore/inferiore
Top/bottom sealing

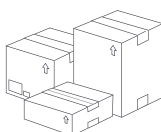

Cartoni di vario formato
Variable carton sizes



Disponibile in acciaio Inox
Stainless steel version

RANDOM TAPE 50 SB SS



PARTICOLARE PNEUMATICO
PNEUMATIC DETAIL



PANNELLO DI CONTROLLO
CONTROL PANEL



RUOTE DI SERIE
WHEELS INCLUDED



VERSIONE ACCIAIO INOX
STAINLESS STEEL VERSION

Caratteristiche tecniche

- ⊕ Peso: 250 Kg
- ⊕ Alimentazione elettrica: 220 Volts - 50 / 60 Hz
- ⊕ Velocità di trasferimento scatola: 20 mt / min
- ⊕ Alimentazione pneumatica: 4 - 6 kgf / cm²
- ⊕ Peso max scatola: 30 Kg
- ⊕ Dimensioni macchina: L 2000 x W 1060 x H 1320 -1550 mm
- ⊕ Rumorosità max: ≤ 75 db
- ⊕ Fungo di emergenza per le normative CE
- ⊕ Nastro adesivo: Kraft, Polipropilene, PVC
- ⊕ Testa nastrante standard: 50 - 75 mm
- ⊕ Altezza piano lavoro: 600 - 830 mm

Technical details

- ⊕ Weight: 250 kg
- ⊕ Power supply: 220 Volts - 50 / 60 Hz
- ⊕ Box transfer speed: 20 mt / min
- ⊕ Air Supply: 4 - 6 kgf / cm²
- ⊕ Maximum box weight: 30 kg
- ⊕ Machine dimensions: L 2000 x W 1060 x H 1320 -1550 mm
- ⊕ Maximum Noise: ≤ 75 db
- ⊕ Emergency stop in compliance with CE regulations
- ⊕ Tape: Kraft, Polypropylene, PVC
- ⊕ Standard taping head: 50 - 75 mm
- ⊕ Working table height: 600 - 830 mm

	DIMENSIONI SCATOLE BOX DIMENSION	
	MINIMO MIN	MASSIMO MAX
LUNGHEZZA LENGTH	150 mm	∞
LARGHEZZA WIDTH	120 mm	480 mm
ALTEZZA HEIGHT	120 mm	500 mm

	NASTRO ADESIVO ADHESIVE TAPE	
	TIPO TYPE	MASSIMO MAX
50 mm	PP PVC KRAFT	990 mt
75 mm	PP PVC KRAFT	990 mt
-	-	-

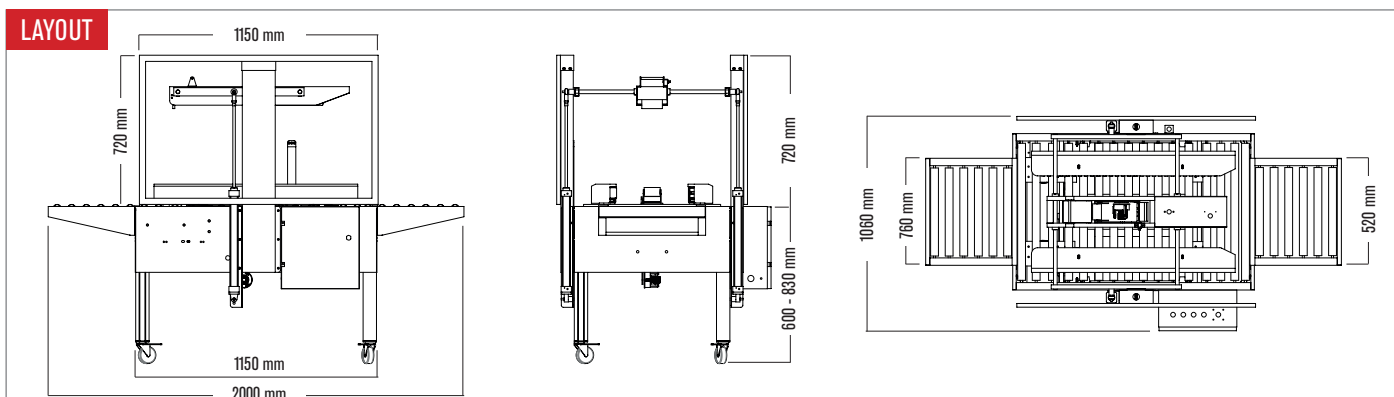

DATI TECNICI | DATA SHEET

Alimentazione elettrica | Power supply

RANDOM TAPE 50 SB

220 volts - 1 ph - 50 / 60 Hz

Potenza Installata | Installed power

0,40 kW

Pressione aria | Air pressure

6 bar

Consumo aria | Air consumption

7 Nlitri / min | 7 Nliter / min

Velocità nastratura | Sealing speed

Fino a 10 / 15 scatole min | Up to 10 / 15 boxes min

Testa nastrante | Taping head

50 - 75 mm

CARATTERISTICHE PRODOTTO LAVORABILE | PRODUCT FEATURES

Dimensioni min. scatola | Min box dimension

L 150 x W 120 x H 120 mm

Dimensioni max. scatola | Max box dimension

L ∞ x W 480 x H 500 mm

Tipologia di scatole | Box type

Scatole di tipo americano | American type boxes

RANDOM TAPE 50 TBB

 220 VOLTS

IT

Nastratrice semiautomatica autodimensionante con quattro cinghie di trascinamento, due superiori e due inferiori, che sigilla con nastro autoadesivo la parte superiore ed inferiore di scatole a formato variabile. Questa nastratrice è particolarmente indicata per scatole alte e corte, instabili o pesanti. L'operatore sromba la scatola, ne piega le falde inferiori, la inserisce nel gruppo centratore per poter riempire la scatola senza doverla tenere con le mani ed abbassa le falde superiori. Successivamente la spinge in macchina, facendo attivare il finecorsa del gruppo testata superiore, il quale sale fino all'altezza della scatola stessa. Durante il passaggio in macchina la scatola viene nastrata simultaneamente sopra e sotto. Compresa di rulliera centratore in ingresso, rulliera in uscita e ruote, costituendo una semplice e pratica postazione di imballaggio.

UK

Semi-automatic and self-dimensioning carton sealer with four feeding flat belts, two top and bottom which seal the top and the bottom of variable size boxes with adhesive tape. This carton sealer is particularly suited for tall or unstable boxes. The operator squares the box, folds the bottom flaps, inserts it in the centering/holding unit where the box can be filled without having to keep it with his hands, folds the top flaps. Thereafter, he guides it into the machine which activates the microswitch of the upper taping head which rises to the top of the box. While the boxes pass through the machine, the top and the bottom flaps will be sealed by the taping heads simultaneously. Machine includes infeed center rollers, outfeed rollers and wheels representing a practical and simple packaging station.

 **Macchine con dimensioni a richiesta**
Customized machines on request

 **Presenza dell'operatore**
With operator

 **Nastratura superiore/inferiore**
Top/bottom sealing

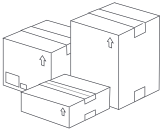
 **Cartoni di vario formato**
Variable carton sizes

 **Disponibile in acciaio Inox**
Stainless steel version
RANDOM TAPE 50 TBB SS



Sistema brevettato per cambio rapido nastro adesivo
Patented system for quick change of adhesive tape



PARTICOLARE PNEUMATICO
PNEUMATIC DETAIL



INTERRUTTORE GENERALE
MAIN POWER SWITCH



RUOTE DI SERIE
WHEELS INCLUDED



CINGHIE DI TRASCINAMENTO
FEEDING BELTS

Caratteristiche tecniche

- ⊕ Peso: 220 Kg
- ⊕ Alimentazione elettrica: 220 Volts - 50 / 60 Hz
- ⊕ Velocità di trasferimento scatola: 22 mt / min
- ⊕ **Cinghie superiori motorizzate**
- ⊕ Pressione aria: 6 kgf / cm²
- ⊕ Peso max scatola: 30 Kg
- ⊕ Dimensioni macchina: L 1961 x W 960 x H 1373 -1673 mm
- ⊕ Rumorosità max: ≤ 75 db
- ⊕ Fungo di emergenza per le normative CE
- ⊕ Nastro adesivo: Kraft, Polipropilene, PVC
- ⊕ Testa nastrante standard: 50 - 75 mm
- ⊕ Altezza piano lavoro: 580 - 830 mm

Technical details

- ⊕ **Weight: 220 Kg**
- ⊕ **Power supply: 220 Volts - 50 / 60 Hz**
- ⊕ **Box transfer speed: 22 mt / min**
- ⊕ **Power top belts**
- ⊕ **Air pressure: 6 kgf / cm²**
- ⊕ **Maximum box weight: 30 kg**
- ⊕ **Machine dimensions: L1961 x W 960 x H 1373 -1673 mm**
- ⊕ **Maximum Noise: ≤ 75 db**
- ⊕ **Emergency stop in compliance with CE regulations**
- ⊕ **Adhesive Tape: Kraft, Polypropylene, PVC**
- ⊕ **Standard Taping head: 50 - 75 mm**
- ⊕ **Working table height: 580 - 830 mm**

	DIMENSIONI SCATOLE BOX DIMENSION	
	MINIMO MIN	MASSIMO MAX
LUNGHEZZA LENGTH	150 mm	∞
LARGHEZZA WIDTH	200 mm	580 mm
ALTEZZA HEIGHT	170 mm	600 mm

	NASTRO ADESIVO ADHESIVE TAPE	
	TIPO TYPE	MASSIMO MAX
50 mm	PP PVC KRAFT	990 mt
75 mm	PP PVC KRAFT	990 mt
-	-	-

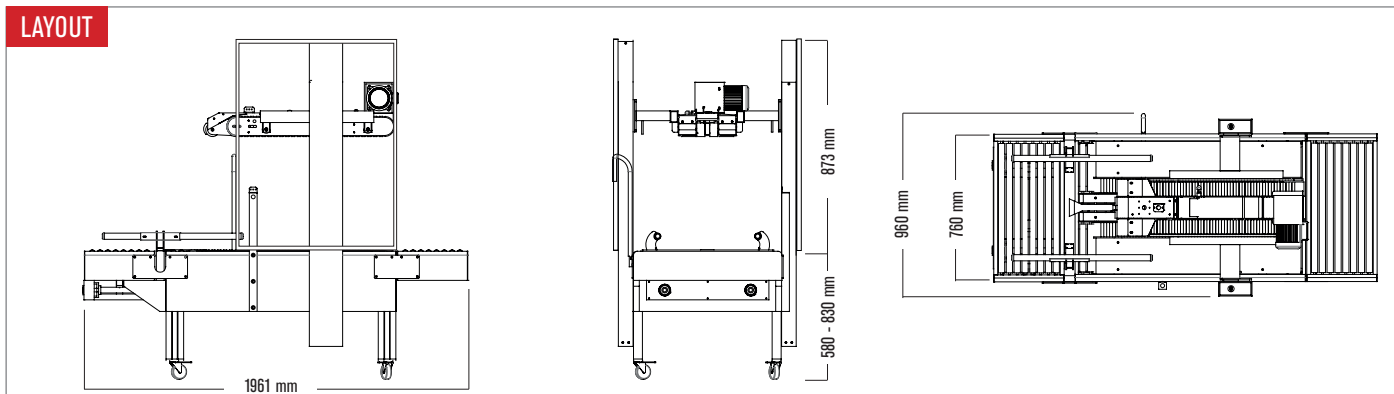

DATI TECNICI | DATA SHEET

Alimentazione elettrica | Power supply

Potenza Installata | Installed power

Pressione aria | Air pressure

Consumo aria | Air consumption

Velocità nastratura | Sealing speed

Testa nastrante | Taping head

RANDOM TAPE 50 TBB

220 volts - 1 ph - 50 / 60 Hz

0,60 kW

6 bar

7 Nltri / min | 7 Nlitr / min

Fino a 15 scatole min | Up to 15 boxes min

50 - 75 mm

CARATTERISTICHE PRODOTTO LAVORABILE | PRODUCT FEATURES

Dimensioni min. scatola | Min box dimension

Dimensioni max. scatola | Max box dimension

Tipologia di scatole | Box type

L 150 x W 200 x H 170 mm

L ∞ x W 580 x H 600 mm

Scatole di tipo americano | American type boxes

AUTO TAPE 50 CF

 380 VOLTS



Nastratrice automatica a dimensionamento manuale e sistema chiudifalde con 2 cinghie di trascinamento laterali. Ripiega automaticamente le quattro falde superiori e sigilla con nastro autoadesivo la parte superiore ed inferiore di lotti di scatole a formato fisso di tipo americano. Le regolazioni sono facili e rapide. Corredata di sensori di rottura e fine nastro adesivo gestita da PLC. Da impiegarsi su linee completamente automatiche, non presidiate da operatori. Possibilità di configurare le regolazioni della scatola sia nella parte destra sia sinistra della macchina. Corredata di rulliere in ingresso ed in uscita e ruote costituendo una semplice e pratica postazione di imballaggio.



Automatic carton sealer with manual box dimensioning and flap closing system equipped with two side belts. It folds the four upper flaps and seals automatically the top and bottom of uniform size American-type boxes. The regulations are fast and easy. Equipped with detectors for the presence or breakage of adhesive tape managed by PLC. To be used on fully automatic lines without operators. Configuration of the box parameters both on the right and left side of the machine. Machine includes infeed and outfeed rollers and wheels represents a practical and simple packaging station.



Macchine con dimensioni a richiesta
Customized machines on request



Disponibile in acciaio Inox
Stainless steel version
AUTO TAPE 50 CF SS

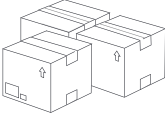

Sensori di rottura e fine nastro.
Break and end of belt sensors.

Cartoni monofornato
Uniform cartons



Nastratura superiore/inferiore
Top/bottom sealing



Assenza dell'operatore
Withtot operator



PANNELLO DI CONTROLLO CON PLC
CONTROL PANEL WITH PLC



SISTEMA DI TRASCINAMENTO SCATOLA
BOX FEEDING SYSTEM



DISPOSITIVO PNEUMATICO CHIUDIFALDE
PNEUMATIC FLAP CLOSURE DEVICE



VERSIONE ACCIAIO INOX
STAINLESS STEEL VERSION

Caratteristiche tecniche

- ⊕ Peso: 280 Kg
- ⊕ Alimentazione : 380 Volt - 50 / 60 Hz
- ⊕ Velocità di trasferimento scatola: 19 mt / min
- ⊕ Peso max scatola: 30 Kg
- ⊕ Dimensioni macchina: L 2536 x W 1021 x H 1953 -2153 mm
- ⊕ Fungo di emergenza per le normative CE
- ⊕ Nastro adesivo: Kraft, Polipropilene, PVC
- ⊕ Testa nastrante standard: 50 - 75 mm
- ⊕ Altezza piano lavoro: 660 - 860 mm
- ⊕ Sensori di lettura fine nastro gestita da PLC
- ⊕ Sensori rottura nastro gestita da PLC
- ⊕ Sistema di regolazioni scatola destro e sinistro
- ⊕ Segnalatore luminoso di allarme

Technical details

- ⊕ Weight: 280 kg
- ⊕ Power supply: 380 Volts - 50 / 60 Hz
- ⊕ Box transfer speed: 19 mt / min
- ⊕ Maximum box weight: 30 kg
- ⊕ Machine dimensions: L 2536 x W 1021 x H 1953 -2153 mm
- ⊕ Emergency stop in compliance with CE regulations
- ⊕ Adhesive tape: Kraft, Polypropylene, PVC
- ⊕ Standard taping head: 50 - 75 mm
- ⊕ Working table height: 660 - 860 mm
- ⊕ Tape presence detector managed by PLC
- ⊕ Tape break detector managed by PLC
- ⊕ Left and right box adjustment system
- ⊕ Warning light

	DIMENSIONI SCATOLE BOX DIMENSION	
	MINIMO MIN	MASSIMO MAX
LUNGHEZZA LENGTH	200 mm	600 mm
LARGHEZZA WIDTH	150 mm	500 mm
ALTEZZA HEIGHT	120 mm	480 mm

	NASTRO ADESIVO ADHESIVE TAPE	
	TIPO TYPE	MASSIMO MAX
50 mm	PP PVC KRAFT	990 mt
75 mm	PP PVC KRAFT	990 mt
-	-	-

LAYOUT

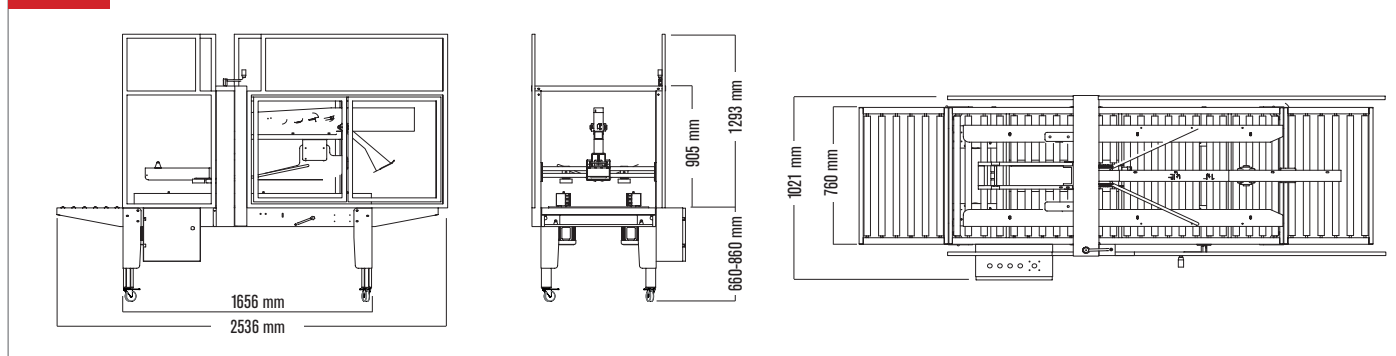

DATI TECNICI | DATA SHEET

Alimentazione elettrica | Power supply

AUTO TAPE 50 CF

380 volts - 3 ph - 50 / 60 Hz

Potenza Installata | Installed power

0,40 kW

Pressione aria | Air pressure

6 bar

Consumo aria | Air consumption

7 Nltri / min | 7 Nlitr / min

Velocità nastratura | Sealing speed

Fino a 8 / 10 scatole min | Up to 8 / 10 boxes min

Testa nastrante | Taping head

50 - 75 mm

CARATTERISTICHE PRODOTTO LAVORABILE | PRODUCT FEATURES

Dimensioni min. scatole | Min box dimension

L 200 x W 150 x H 120 mm

Dimensioni max. scatole | Max box dimension

L 600 x W 500 x H 480 mm

Tipologia di scatole | Box type

Scatole di tipo americano | American type boxes

AUTO TAPE 50 CF HM

 380 VOLTS



Macchina automatica a dimensionamento manuale e sistema chiudifalde con 2 cinghie di trascinamento laterali e sigillatura con colla a caldo. Incolla e ripiega le quattro falde superiori di lotti di scatole a formato fisso di tipo americano. Le regolazioni sono facili e rapide. Da impiegarsi su linee completamente automatiche, non presidiate da operatori. La macchina è predisposta per essere abbinata ai gruppi di fusione ed applicazione colla maggiormente diffusi in commercio. Corredata di rulliere in ingresso ed in uscita, ruote, e gruppo fusore colla Nordson mod. "MESA 6,2 H/G".



Automatic carton sealer with manual box dimensioning, flap closing system, two side belts and hot melt system. It seals and folds the four upper flaps of uniform sized American-type boxes. Easy and fast regulations. To be used on fully automatic lines without operators. Machine can work with the most important hot melt systems on the market. It is equipped with infeed and outfeed rollers, wheels and Nordson hot melt system, mod. "MESA 6,2 H/G".



Macchine con
dimensioni a richiesta

Customized machines
on request



Disponibile in
acciaio Inox
Stainless steel version

AUTO TAPE 50 CF HM SS

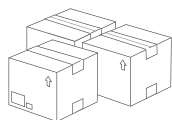

Cartoni monofornato
Uniform cartons



Sigillatura superiore colla a caldo
Top hot melt sealing



Assenza dell'operatore
Withtot operator



SISTEMA CHIUDIFALDE
FLAP CLOSING SYSTEM



SISTEMA CHIUSURA COLLA A CALDO
GLUE CLOSER SYSTEM



GRUPPO FUSORE COLLA A CALDO
HOT MELT NORDSON



PANNELLO DI CONTROLLO
CONTROL PANEL

Caratteristiche tecniche

- ⊕ Peso: 300 Kg
- ⊕ Alimentazione : 380 Volt - 50 / 60 Hz
- ⊕ Velocità di trasferimento scatola: 19 mt / min
- ⊕ Pressione aria: 6 kgf / cm²
- ⊕ Peso max scatola: 30 Kg
- ⊕ Dimensioni macchina: L 2536 x W 1021 x H 1953 -2153 mm
- ⊕ Rumorosità max: ≤ 75 db
- ⊕ Fungo di emergenza per le normative CE
- ⊕ **Gruppo fusore colla a caldo Nordson**
- ⊕ Testa nastrante standard: 50 - 75 mm
- ⊕ Altezza piano lavoro: 660 - 860 mm

Technical details

- ⊕ **Weight: 300 kg**
- ⊕ **Power supply: 380 Volts - 50 / 60 Hz**
- ⊕ **Box transfer speed: 19 mt / min**
- ⊕ **Air pressure: 6 kgf / cm²**
- ⊕ **Maximum box weight: 30 kg**
- ⊕ **Machine dimensions: L 2536 x W 1021 x H 1953 -2153 mm**
- ⊕ **Maximum Noise: ≤ 75 db**
- ⊕ **Emergency stop in compliance with CE regulations**
- ⊕ **Hot Melt Nordson**
- ⊕ **Standard taping head: 50 - 75 mm**
- ⊕ **Working table height: 660 - 860 mm**

	DIMENSIONI SCATOLE BOX DIMENSION	
	MINIMO MIN	MASSIMO MAX
LUNGHEZZA LENGTH	200 mm	600 mm
LARGHEZZA WIDTH	150 mm	500 mm
ALTEZZA HEIGHT	120 mm	480 mm

LAYOUT

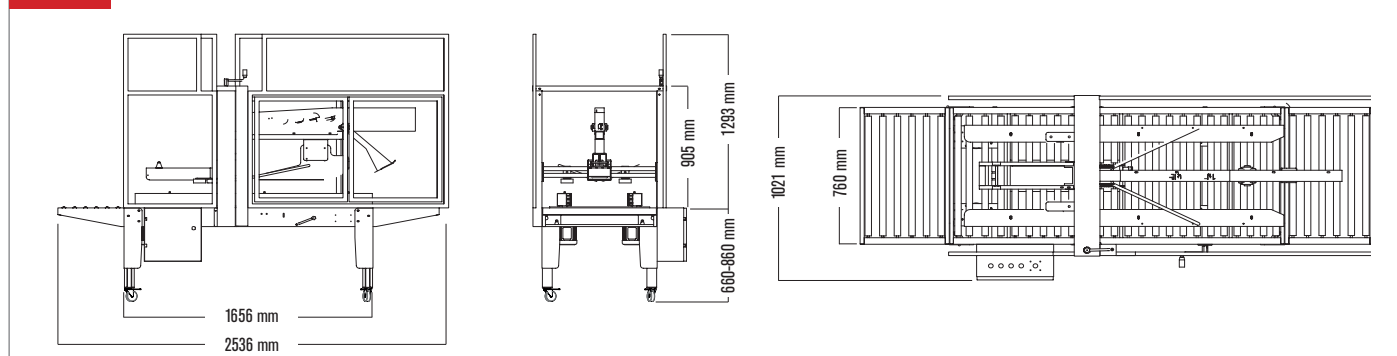

DATI TECNICI | DATA SHEET

Alimentazione elettrica | Power supply

Potenza Installata | Installed power

Pressione aria | Air pressure

Consumo aria | Air consumption

Velocità nastratura | Sealing speed

Metodo di sigillatura | Sealing method

AUTO TAPE 50 CF HM

380 volts - 3 ph - 50 / 60 Hz

0,40 kW

6 bar

7 Nltri / min | 7 Nlitr / min

Fino a 8 / 10 scatole min | Up to 8 / 10 boxes min

Colla a caldo | Hot Melt

CARATTERISTICHE PRODOTTO LAVORABILE | PRODUCT FEATURES

Dimensioni min. scatole | Min box dimension

Dimensioni max. scatole | Max box dimension

Tipologia di scatole | Box type

L 200 x W 150 x H 120 mm

L 600 x W 500 x H 480 mm

Scatole di tipo americano | American type boxes

MATIC TAPE 50 CF - 50 CF HM

 380 VOLTS

IT

Nastratrice autodimensionante e sistema chiudifalde che sigilla con nastro adesivo la parte inferiore e superiore della scatola di tipo americano a formato variabile. La macchina è destinata ad essere inserita in linee automatiche non presidiate da operatori. Struttura del corpo macchina in lamiera d'acciaio piegata saldata e verniciata. Il trascinamento dei cartoni avviene tramite quattro cinghie laterali inferiori comandate da quattro motori, la macchina si regola automaticamente sui diversi formati, dopodichè chiude le falde e nastra le scatole in automatico. Gli azionamenti sono di tipo pneumatico e la gestione elettronica è governata da PLC SIEMENS.

UK

Automatic and self dimensioning carton sealer with flap closing system. It folds the four upper flaps and seals the top and bottom variable sized american-type boxes automatically. To be used on fully automatic lines without operators. Machine structure in folded, welded and painted steel sheet. Box feeding is regulated by four lateral bottom belts controlled by four motors. The machine self adjusts to the boxes, automatically folds the four upper flaps and seals them. Pneumatic drives and electronic system controlled by SIEMENS PLC.



Macchine con dimensioni a richiesta
Customized machines on request



Disponibile in acciaio Inox
Stainless steel version

MATIC TAPE 50 CF SS
MATIC TAPE 50 CF HM SS





Cartoni di vario formato
Variable carton sizes



Nastratura superiore/inferiore
Top/bottom sealing



Assenza dell'operatore
Withtot operator



DISPOSITIVO PNEUMATICO CHIUDIFALDE
PNEUMATIC FLAP CLOSURE DEVICE



SISTEMA CHIUDIFALDE
FLAP CLOSING SYSTEM



QUADRO ELETTRICO GESTITO DA PLC
MACHINE CONTROLLED BY PLC



DISPLAY TOUCH SCREEN DA 7,2" A COLORI
DIGITAL COLOR TOUCH SCREEN 7,2"

Caratteristiche tecniche

- ⊕ Peso: 820 Kg
- ⊕ Alimentazione elettrica: 380 Volt - 50 / 60 Hz
- ⊕ Velocità di trasferimento scatola: 19 mt / min
- ⊕ Pressione aria: 6 kgf / cm²
- ⊕ Peso max scatola: 30 Kg
- ⊕ Dimensioni macchina: L 2650 x W 1370 x H 1948 - 2058 mm
- ⊕ Fungo di emergenza per le normative CE
- ⊕ Nastro adesivo: Kraft, Polipropilene, PVC
- ⊕ **Modello con chiusura con colla a caldo (Matic Tape 50 CF HM)**
- ⊕ Testa nastrante standard: 50 - 75 mm
- ⊕ Altezza piano lavoro: 640 - 750 mm

Technical details

- ⊕ **Weight: 820 kg**
- ⊕ **Power supply: 380 Volt - 50 / 60 Hz**
- ⊕ **Box transfer speed: 19 mt / min**
- ⊕ **Air pressure: 6 kgf / cm²**
- ⊕ **Maximum box weight: 30 kg**
- ⊕ **Machine dimensions: L 2000 x W 1370 x H 1940 - 2058 mm**
- ⊕ **Emergency stop in compliance with CE regulations**
- ⊕ **Adhesive tape: Kraft, Polypropylene, PVC**
- ⊕ **Hot Melt model (Matic Tape 50 CF HM)**
- ⊕ **Standard taping head: 50 - 75 mm**
- ⊕ **Working table height: 640 - 750 mm**

	DIMENSIONI SCATOLE BOX DIMENSION	
	MINIMO MIN	MASSIMO MAX
LUNGHEZZA LENGTH	250 mm	500 mm
LARGHEZZA WIDTH	200 mm	450 mm
ALTEZZA HEIGHT	150 mm	400 mm

	NASTRO ADESIVO ADHESIVE TAPE	
	TIPO TYPE	MASSIMO MAX
50 mm	PP PVC KRAFT	990 mt
75 mm	PP PVC KRAFT	990 mt
-	-	-

LAYOUT

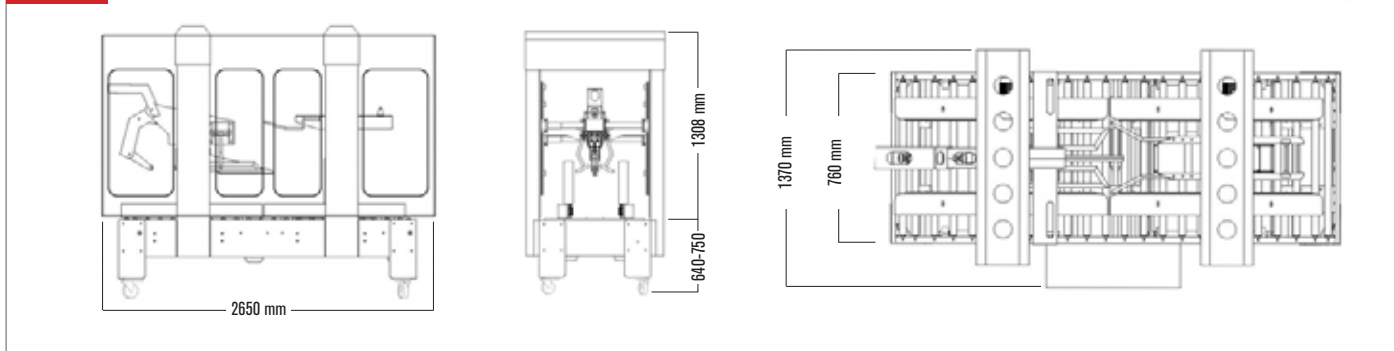

DATI TECNICI | DATA SHEET

	MATIC TAPE 50 CF	MATIC TAPE 50 CF HM
Alimentazione elettrica Power supply	380 volts 3 ph - 50/60 Hz	380 volts - 3 ph - 50 / 60 Hz
Potenza Installata Installed power	1,20 kW	1,20 kW
Pressione aria Air pressure	6 bar	6 bar
Consumo aria Air consumption	5 - 6 Nltri / min 5 - 6 Nliter / min	5 - 6 Nltri / min 5 - 6 Nliter / min
Velocità nastratura Sealing speed	Fino a 6 / 8 scatole min Up to 6 / 8 boxes min	Fino a 6 / 8 scatole min Up to 6 / 8 boxes min
Testa nastrante Taping head	50 - 75 mm	50 - 75 mm
Metodo di sigillatura Sealing method	Nastro Adhesive tape	Nastro - Colla a caldo Adhesive tape - Hot Melt

CARATTERISTICHE PRODOTTO LAVORABILE | PRODUCT FEATURES

Dimensioni min. scatole Min box dimension	L 250 x W 200 x H 150 mm	L 250 x W 200 x H 150 mm
Dimensioni max. scatole Max box dimension	L 500 x W 450 x H 400 mm	L 500 x W 450 x H 400 mm
Tipologia di scatole Box type	Scatole di tipo americano American type boxes	Scatole di tipo americano American type boxes

CORNER TAPE 50 TBB – 50A TBB

 220 VOLTS



Nastratrice automatica disponibile nella versione a dimensionamento manuale della scatola (Corner tape 50 TBB) o autodimensionante (Corner Tape 50A TBB). La caratteristica principale di questa macchina è quella di nastrare automaticamente i lati superiori ed inferiori della scatola applicando 4 strisce di autoadesivo ad "U". La scatola viene trasportata da una rulliera motorizzata verso uno spintore pneumatico che la direziona (con una rotazione di 90° rispetto all'inserimento) verso le quattro teste nastranti. A nastratura completata la scatola continua il percorso verso un sistema di cilindri ad aria che completano l'operazione abbassando i lembi del nastro e sigillando ermeticamente il pacco su tutti i lati. Possibilità di inserimento in linee automatiche non presidiate da operatori.



Automatic carton sealer available in the version with manual box dimensioning (Corner tape 50 TBB) or self-dimensioning (Corner Tape 50A TBB). The main feature of this machine is that it automatically tapes the upper and lower edges of the box by applying 4 "U" strips of adhesive tape. The box is transported by a motorized roller conveyor to a pneumatic pusher that diverts it to 90 ° of its original position and feeds it towards the four taping heads. Once the taping is completed, the box feeds to an air cylinder system that lowers the edges of the tape and hermetically seals the package on all sides. Possibility to put the machine in a fully automatic line without operator.

 **Macchine con dimensioni a richiesta**
Customized machines on request

 **Assenza dell'operatore**
Without operator

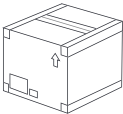
 **Nastratura ai 4 angoli**
4 Edge sealing

 **Disponibile in acciaio Inox**
Stainless steel version
CORNER TAPE 50 TBB SS
CORNER TAPE 50A TBB SS



PARTICOLARE MACCHINA
MACHINE DETAIL



DISPLAY TOUCH SCREEN DA 7,2" A COLORI
DIGITAL COLOR TOUCH SCREEN 7,2"



MACCHINA GESTITA DA PLC
MACHINE CONTROLLED BY PLC



QUATTRO TESTE DI NASTRATURA
FOUR TAPING HEADS

Caratteristiche tecniche

- ⊕ Peso: 480 Kg
- ⊕ Alimentazione elettrica: 220 Volts - 50 / 60 Hz
- ⊕ Velocità di trasferimento scatola: 19 mt / min
- ⊕ Pressione aria: 6 kgf / cm²
- ⊕ **Versione autodimensionante (Corner Tape 50A TBB)**
- ⊕ **Versione manuale (Corner Tape 50 TBB)**
- ⊕ Consumo aria: 11 Nltri / min
- ⊕ Peso max scatola: 30 Kg
- ⊕ Dimensioni macchina: L 2168 x W 1373 x H 1335 - 1485 mm
- ⊕ Fungo di emergenza per le normative CE
- ⊕ Nastro adesivo: Kraft, Polipropilene, PVC
- ⊕ Altezza piano lavoro: 600 - 750 mm

Technical details

- ⊕ **Weight: 480 kg**
- ⊕ **Power supply: 220 Volts - 50 / 60 Hz**
- ⊕ **Box transfer speed: 19 mt / min**
- ⊕ **Air pressure: 6 kgf / cm²**
- ⊕ **Self-dimensioning version (Corner Tape 50A TBB)**
- ⊕ **Manual version (Corner Tape 50 TBB)**
- ⊕ **Air consuption: 11 Nliter / min**
- ⊕ **Maximum box weight: 30 kg**
- ⊕ **Machine dimensions: L 2168 x W 1373 x H 1335 - 1485 mm**
- ⊕ **Emergency stop in compliance with CE regulations**
- ⊕ **Adhesive tape: Kraft, Polypropylene, PVC**
- ⊕ **Working table height: 600 - 750 mm**

	DIMENSIONI SCATOLE BOX DIMENSION	
	MINIMO MIN	MASSIMO MAX
LUNGHEZZA LENGTH	340 mm	670 mm
LARGHEZZA WIDTH	200 mm	470 mm
ALTEZZA HEIGHT	200 mm	500 mm

	NASTRO ADESIVO ADHESIVE TAPE	
	TIPO TYPE	MASSIMO MAX
50 mm	PP PVC KRAFT	990 mt
75 mm	PP PVC KRAFT	990 mt
-	-	-

LAYOUT

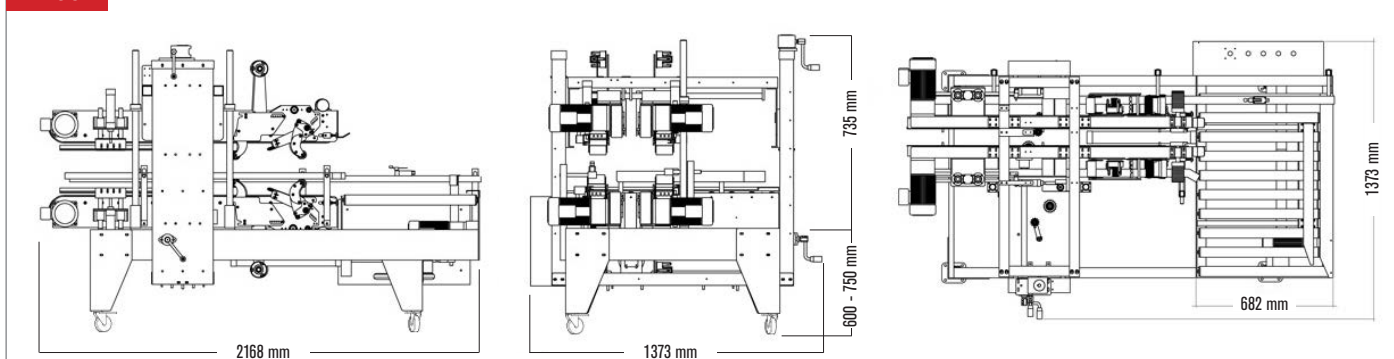

DATI TECNICI | DATA SHEET

	CORNER TAPE 50 TBB	CORNER TAPE 50A TBB
Alimentazione elettrica Power supply	220 volts - 1 ph - 50 / 60 Hz	220 volts - 1 ph - 50 / 60 Hz
Potenza Installata Installed power	1 kW	1 kW
Pressione aria Air pressure	6 bar	6 bar
Consumo aria Air consumption	11 Nltri / min 11 Nliter / min	11 Nltri / min 11 Nliter / min
Velocità nastratura Sealing speed	Fino a 4 / 6 scatole min Up to 4 / 6 boxes min	Fino a 4 / 6 scatole min Up to 4 / 6 boxes min
Testa nastrante Taping head	50 - 75 mm	50 - 75 mm
Dimensionamento scatola Box sizing	Manuale Manual	Autodimensionante Self-dimensioning

CARATTERISTICHE PRODOTTO LAVORABILE | PRODUCT FEATURES

Dimensioni min. scatole Min box dimension	L 340 x W 200 x H 200 mm	L 340 x W 200 x H 200 mm
Dimensioni max. scatole Max box dimension	L 670 x W 470 x H 500 mm	L 670 x W 470 x H 500 mm
Tipologia di scatole Box type	Scatole di tipo americano American type boxes	Scatole di tipo americano American type boxes

COMBI PACKER 50 SB – 50E SB

 220 VOLTS

IT

Nastratrice semiautomatica a dimensionamento manuale combinata con reggiatrice automatica ad arco. L'avanzamento della scatola avviene mediante due cinghie motorizzate laterali comandate da due motori, garantendo così la massima uniformità di scorrimento. Il risultato è un perfetto allineamento delle falde e quindi una sigillatura ottimale, che viene effettuata dalle performanti teste nastranti. La macchina può essere programmata per eseguire solo nastratura scatola, nastratura e una reggiatura oppure nastratura e due reggiature in parallelo. La distanza delle reggiature può essere regolata spostando le fotocellule poste su guide di scorrimento. Può essere utilizzata da operatori non specializzati poiché richiede semplicissime regolazioni. Corredata di rulliera in ingresso, lama fermascatola e ruote costituendo una semplice e pratica postazione di imballaggio.

UK

A combined machine, semi-automatic and manual dimensioning carton sealer with automatic arch strapping machine. Box feeding is regulated by two lateral belts controlled by two motors, ensuring the maximum sliding uniformity. The result is a perfect alignment of box flaps and optimum sealing, thanks to the efficient taping head. The machine can be programmed for box taping/taping and strapping or taping and two strapping in parallel. The strapping distance can be adjusted by regulating the photocells placed on slide guides. It can be used by non-specialized operators because the machine requires simple adjustment operations. Machine is equipped with infeed rollers, blade to stop the box and wheels represents a practical and simple packaging station.



Macchine con dimensioni a richiesta

Customized machines on request

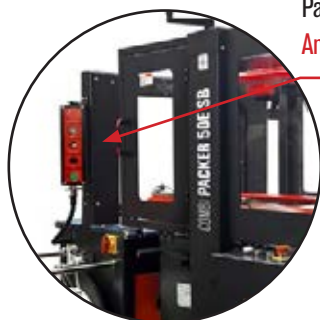

Pannello comandi analogico per Combi Packer 50E SB
Analog control panel for Combi Pack 50 E SB





Disponibile in acciaio Inox
Stainless steel version

COMBI PACKER 50 SB SS
COMBI PACKER 50E SB SS



Presenza dell'operatore
With operator

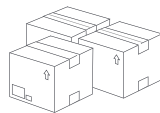

Cartoni monoformato
Uniform cartons



Nastratura superiore/inferiore + reggiatura
Top/bottom sealing + Strapping



PANNELLO COMANDI ANALOGICO REGGIATRICE
ANALOGUE STRAPPING CONTROL PANEL



PANNELLO COMANDI DIGITALE REGGIATRICE
DIGITAL STRAPPING CONTROL PANEL



SENSORE PER REGGIATURA AUTOMATICA
AUTOMATIC STRAPPING SENSOR



CARICAMENTO AUTOMATICO DELLA REGGIA
AUTOMATIC LOADING OF THE STRAP

Caratteristiche tecniche

- ⊕ Peso: 450 Kg
- ⊕ **Pannello comandi digitale reggiatrice (Combi Packer 50 SB)**
- ⊕ **Dispositivo taglio reggia**
- ⊕ Velocità di trasferimento scatola: 19 mt / min
- ⊕ Dimensione arco: 650 x 500 mm
- ⊕ Tensione max reggia: fino a 45 Kg
- ⊕ **Utilizza reggia da: 5 - 9 - 12 mm (Combi Packer 50 SB)**
- ⊕ **Utilizza reggia da: 9 - 12 mm (Combi Packer 50E SB)**
- ⊕ Spessore reggia: 0,45 - 0,65 mm
- ⊕ Peso max scatola: 30 Kg
- ⊕ Fungo di emergenza per le normative CE
- ⊕ Dimensioni macchina: L 1794 x W 1303 x H 1613 mm (standard)
- ⊕ Altezza piano lavoro: 850 mm

Technical details

- ⊕ **Weight: 450 Kg**
- ⊕ **Strapping touch control (Combi Packer 50 SB)**
- ⊕ **Strap cutting system (Combi Packer 50 SB)**
- ⊕ **Box transfer speed: 19 mt / min**
- ⊕ **Arch size: 650 x 500 mm**
- ⊕ **Maximum strap tension: up to 45 Kg**
- ⊕ **Strap size: 5 - 9 - 12 mm (Combi Packer 50 SB)**
- ⊕ **Strap size: 9 - 12 mm (Combi Packer 50E SB)**
- ⊕ **Strap thickness: 0,45 - 0,65 mm**
- ⊕ **Maximum box weight: 30 kg**
- ⊕ **Emergency stop in compliance with CE regulations**
- ⊕ **Machine dimensions: L 1794 x W 1303 x H 1613 mm (standard)**
- ⊕ **Working table height: 850 mm**

	DIMENSIONI SCATOLE BOX DIMENSION	
	MINIMO MIN	MASSIMO MAX
LUNGHEZZA LENGTH	150 mm	∞
LARGHEZZA WIDTH	120 mm	480 mm
ALTEZZA HEIGHT	120 mm	480 mm

	NASTRO ADESIVO ADHESIVE TAPE	
	TIPO TYPE	MASSIMO MAX
50 mm	PP PVC KRAFT	990 mt
75 mm	PP PVC KRAFT	990 mt
-	-	-

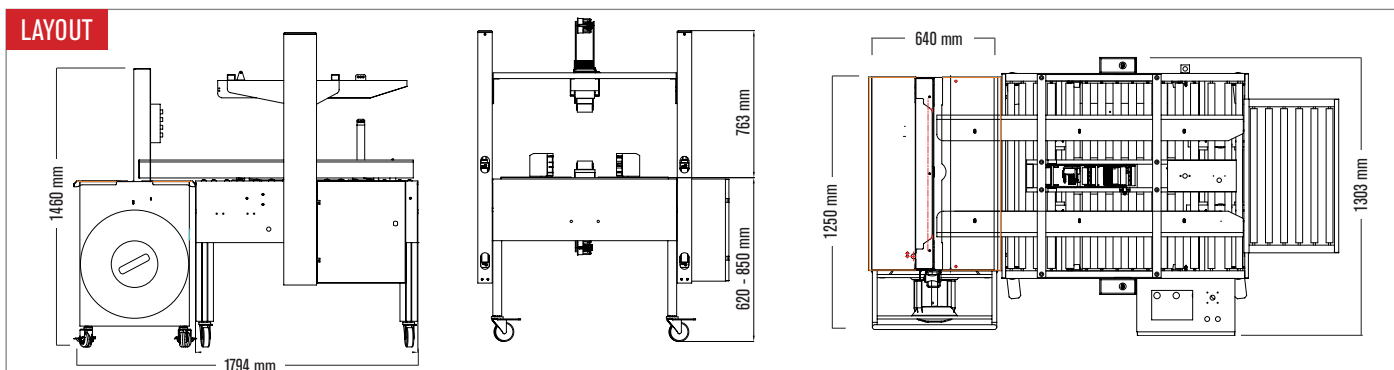

DATI TECNICI DATA SHEET	COMBI PACKER 50 SB	COMBI PACKER 50E SB
Alimentazione elettrica Power supply	220 volts - 1 ph - 50 / 60 Hz	220 volts - 1 ph - 50 / 60 Hz
Potenza Installata nastratrice Installed power	0,40 kW	0,40 kW
Velocità nastratura Sealing speed	Fino a 6 / 8 scatole min Up to 6 / 8 boxes min	Fino a 6 / 8 scatole min Up to 6 / 8 boxes min
Testa nastrante Taping head	50 - 75 mm	50 - 75 mm
Potenza installata reggiatrice Installed power	0,70 kW	0,70 kW
Velocità reggiatura Strapping speed	65 cicli min 65 cycle min	40 cicli min 40 cycle min
Tipo di reggia Strap type	Reggia in PP 5 - 9 - 12 mm PP strap 5 - 9 - 12 mm	Reggia in PP 9 - 12 mm PP strap 9 - 12 mm
Modello reggiatrice Strapping machine	Speed Strap (arco arch 650 x 500 mm) - Serie Speed	Easy Strap (arco arch 650 x 500 mm) - Serie Easy

CARATTERISTICHE PRODOTTO LAVORABILE | PRODUCT FEATURES

Dimensioni min. scatole Min box dimension	L 150 x W 120 x H 120 mm	L 150 x W 120 x H 120 mm
Dimensioni max. scatole Max box dimension	L ∞ x W 480 x H 480 mm	L ∞ x W 480 x H 480 mm
Tipologia di scatole Box type	Scatole di tipo americano American type boxes	Scatole di tipo americano American type boxes

COMBI PACKER 50 SBR - 50E SBR

 220 VOLTS



Nastratrice autodimensionante combinata con reggiatrice automatica ad arco. L'avanzamento della scatola avviene mediante due cinghie laterali comandate da due motori, garantendo così la massima uniformità di scorrimento. Il risultato è un perfetto allineamento delle falde e quindi una sigillatura ottimale, che viene effettuata dalle performanti teste nastranti. La macchina può essere programmata per eseguire solo nastratura scatola, nastratura e una reggiatura oppure nastratura e due reggiature in parallelo. La distanza delle reggiature viene regolata tramite touch screen. Può essere utilizzata da operatori non specializzati poiché richiede semplicissime regolazioni.



A combined machine, semi-automatic and self dimensioning carton sealer with automatic arch strapping machine. Box feeding is regulated by two lateral belts controlled by two motors, ensuring the maximum sliding uniformity. The result is a perfect alignment of box flaps and optimum sealing, thanks to the efficient taping heads. The machine can be programmed for box taping / taping and strapping or taping and two strapping in parallel. The strapping distance can be adjusted by touch screen. It can be used by non-specialized operators because the machine requires simple adjustment operations.

 **Macchine con dimensioni a richiesta**
Customized machines on request

 **Presenza dell'operatore**
With operator

 **Nastratura superiore/inferiore + reggiatura**
Top/bottom sealing + Strapping

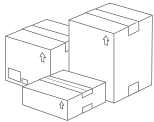
 **Cartoni di vario formato**
Variable carton sizes

 **Disponibile in acciaio Inox**
Stainless steel version
COMBI PACKER 50 SBR SS
COMBI PACKER 50E SBR SS



DISPLAY TOUCH SCREEN DA 7,2" A COLORI
DIGITAL COLOR TOUCH SCREEN 7,2"



CONTROLLO TOUCH REGGIATRICE
TOUCH CONTROL STRAPPING MACHINE



MACCHINA GESTITA DA PLC
MACHINE CONTROLLED BY PLC



REGGIATRICE AUTOMATICA
AUTOMATIC STRAPPING MACHINE

Caratteristiche tecniche

- ⊕ Peso: 450 Kg
- ⊕ Velocità di trasferimento scatola: 19 mt / min
- ⊕ Dimensione arco: 650 x 500 mm
- ⊕ Tensione max reggia: fino a 45 Kg
- ⊕ **Utilizza reggia da: 5 - 9 - 12 mm (Combi Packer 50 SBR)**
- ⊕ **Utilizza reggia da: 9 - 12 mm (Combi Packer 50E SBR)**
- ⊕ Spessore reggia: 0,45 - 0,65 mm
- ⊕ Fungo di emergenza per le normative CE
- ⊕ Peso max scatola: 30 Kg
- ⊕ Dimensioni macchina: L 1794 x W 1303 x H 1613 mm
- ⊕ Altezza piano lavoro: 850 mm

Technical details

- ⊕ **Weight: 450 Kg**
- ⊕ **Box transfer speed: 19 mt / min**
- ⊕ **Arch size: 650 x 500 mm**
- ⊕ **Maximum strap tension: up to 45 Kg**
- ⊕ **Strap size: 5 - 9 - 12 mm (Combi packer 50 SBR)**
- ⊕ **Strap size: 9 - 12 mm (Combi packer 50E SBR)**
- ⊕ **Strap thickness: 0,45 - 0,65 mm**
- ⊕ **Emergency stop in compliance with CE regulations**
- ⊕ **Maximum box weight: 30 kg**
- ⊕ **Machine dimensions: L 1794 x W 1303 x H 1613 mm**
- ⊕ **Working table height: 850 mm**

	DIMENSIONI SCATOLE BOX DIMENSION	
	MINIMO MIN	MASSIMO MAX
LUNGHEZZA LENGTH	150 mm	∞
LARGHEZZA WIDTH	120 mm	480 mm
ALTEZZA HEIGHT	120 mm	500 mm

	NASTRO ADESIVO ADHESIVE TAPE	
	TIPO TYPE	MASSIMO MAX
50 mm	PP PVC KRAFT	990 mt
75 mm	PP PVC KRAFT	990 mt
-	-	-

LAYOUT

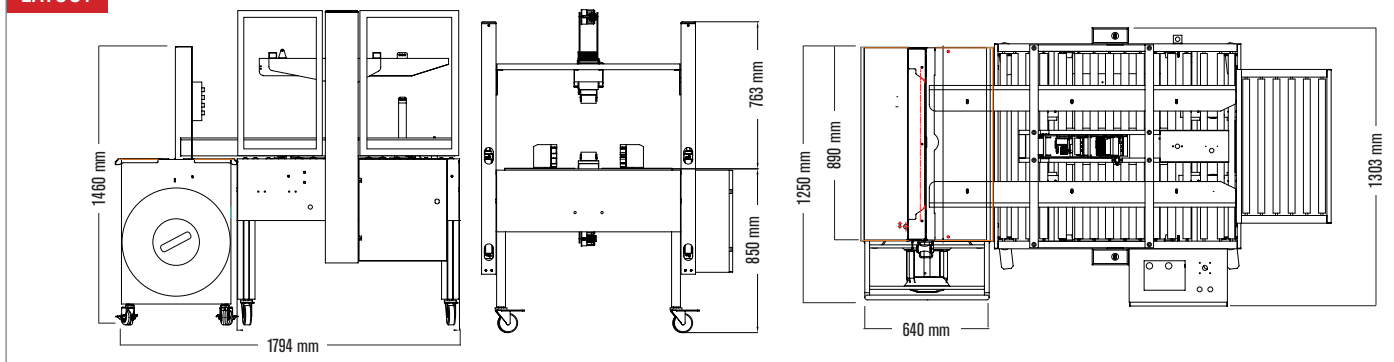

DATI TECNICI DATA SHEET	COMBI PACKER 50 SBR	COMBI PACKER 50E SBR
Alimentazione elettrica Power supply	220 volts 1 ph - 50/60 Hz	220 volts 1 ph - 50/60 Hz
Potenza Installata nastratrice Installed power	0.40 kW	0.40 kW
Pressione aria Air pressure	6 bar	6 bar
Consumo aria Air consumption	7 Nltri / min 7 Nlter / min	7 Nltri / min 7 Nlter / min
Velocità nastratura Sealing speed	Fino a 6 / 8 scatole min Up to 6 / 8 boxes min	Fino a 6 / 8 scatole min Up to 6 / 8 boxes min
Testa nastrante Taping head	50 - 75 mm	50 - 75 mm
Potenza Installata reggiatrice Installed power	0.70 kW	0.70 kW
Velocità reggiatura Strapping speed	65 cicli min 65 cycle min	40 cicli min 40 cycle min
Tipo di reggia Strap type	Reggia in PP 5 - 9 - 12 mm PP strap 5 - 9 - 12 mm	Reggia in PP 9 - 12 mm PP strap 9 - 12 mm
Modello reggiatrice Strapping machine	Speed Strap (arco arch 650 x 500 mm)	Easy Strap (arco arch 650 x 500 mm)

CARATTERISTICHE PRODOTTO LAVORABILE | PRODUCT FEATURES

Dimensioni min. scatole Min box dimension	L 150 x W 120 x H 120 mm	L 150 x W 120 x H 120 mm
Dimensioni max. scatole Max box dimension	L ∞ x W 480 x H 500 mm	L ∞ x W 480 x H 500 mm
Tipologia di scatole Box type	Scatole di tipo americano American type boxes	Scatole di tipo americano American type boxes

COMBI PACKER 50A CF



Nastratrice automatica a dimensionamento manuale e sistema chiudifalde con 2 cinghie di trascinamento laterali combinata con reggiatrice automatica ad arco. Ripiega automaticamente le quattro falde superiori e sigilla con nastro autoadesivo la parte superiore ed inferiore dei lotti delle scatole a formato fisso di tipo americano. Le regolazioni sono facili e rapide. Da impiegarsi su linee completamente automatiche, non presidiate da operatori. La macchina è abbinata ad una reggiatrice modello Speed Strap con arco da 650 x 500 che supporta reggie in PP da 5 - 9 e 12 mm.



Automatic carton sealer with manual box dimensioning and flap closing system equipped with two side belts combined with an automatic strapping machine with arch. It folds the four upper flaps and seals automatically the top and bottom of uniform size American-type boxes. The regulations are fast and easy. To be used on fully automatic lines without operators. The machine is combined with a Speed Strap strapping machine with 650 x 500 arch that works with 5 - 9 and 12mm PP strap.

 **Macchine con dimensioni a richiesta**
Customized machines on request

 **Assenza dell'operatore**
Without operator

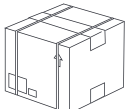
 **Nastratura superiore/inferiore + reggiatura**
Top/bottom sealing + Strapping

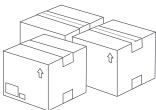
 **Cartoni monofornato**
Uniform carton

 **Disponibile in acciaio Inox**
Stainless steel version
COMBI PACKER 50A CF SS



PANNELLO DI CONTROLLO
CONTROL PANEL



GRUPPO PNEUMATICO CON VALVOLA DI EMERGENZA
PNEUMATIC GROUP WITH EMERGENCY VALVE

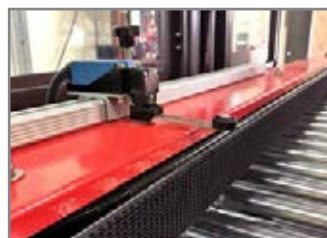

NASTRI TRASPORTATORI MOTORIZZATI
POWER BELTS CONVEYOR



SENSORE PER REGGIATURA AUTOMATICA
AUTOMATIC STRAPPING SENSOR

Caratteristiche tecniche

- ⊕ Peso: 450 Kg
- ⊕ Alimentazione elettrica nastratrice: 380 Volts - 50 / 60 Hz
- ⊕ Alimentazione elettrica reggiatrice: 220 Volts - 50 / 60 Hz
- ⊕ Velocità di trasferimento scatola: 19 mt / min
- ⊕ Dimensione arco: 650 x 500 mm
- ⊕ Tensione max reggia: fino a 45 Kg
- ⊕ **Utilizza reggia da: 5 - 9 - 12 mm**
- ⊕ Spessore reggia: 0,45 - 0,65 mm
- ⊕ Peso max scatola: 30 Kg
- ⊕ Dimensioni macchina: L 2820 x W 1250 x H 2143 mm
- ⊕ Altezza piano lavoro: 850 mm

Technical details

- ⊕ **Weight: 450 Kg**
- ⊕ **Power supply taping machine: 380 Volts - 50 / 60 Hz**
- ⊕ **Power supply strapping machine: 220 Volts - 50 / 60 Hz**
- ⊕ **Box transfer speed: 19 mt / min**
- ⊕ **Arch size: 650 x 500 mm**
- ⊕ **Maximum strap tension: up to 45 Kg**
- ⊕ **Strap size: 5 - 9 - 12 mm**
- ⊕ **Strap thickness: 0,45 - 0,65 mm**
- ⊕ **Maximum box weight: 30 kg**
- ⊕ **Machine dimensions: L 2820 x W 1250 x H 2143 mm**
- ⊕ **Working table height: 850 mm**

	DIMENSIONI SCATOLE BOX DIMENSION	
	MINIMO MIN	MASSIMO MAX
LUNGHEZZA LENGTH	200 mm	600 mm
LARGHEZZA WIDTH	150 mm	500 mm
ALTEZZA HEIGHT	120 mm	480 mm

	NASTRO ADESIVO ADHESIVE TAPE	
	TIPO TYPE	MASSIMO MAX
50 mm	PP PVC KRAFT	990 mt
75 mm	PP PVC KRAFT	990 mt
-	-	-

LAYOUT

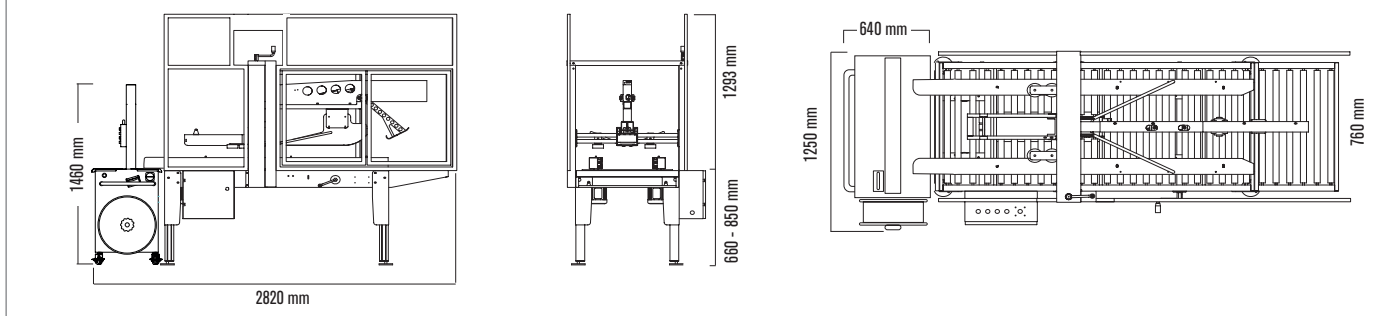

DATI TECNICI | DATA SHEET

COMBI PACKER 50A CF

Alimentazione elettrica nastratrice Power supply	380 volts - 3 ph - 50 / 60 Hz
Potenza Installata nastratrice Installed power taping machine	0,40 Kw
Pressione aria Air pressure	6 bar
Consumo aria Air consumption	7 Nltri / min 7 Nlitr / min
Velocità nastratura Sealing speed	Fino a 8/10 scatole min Up to 8/10 boxes min
Testa nastrante Taping head	50 - 75 mm
Alimentazione elettrica reggiatrice Power supply strapping machine	220 volts - 1 ph - 50 / 60 Hz
Potenza Installata reggiatrice Installed power	0,70 Kw
Velocità reggiatura Strapping speed	65 cicli min 65 cycle min
Tipo di reggia Strap type	Reggia in PP 5 - 9 - 12 mm PP strap 5 - 9 - 12 mm
Modello reggiatrice Strapping machine	Speed Strap (arco arch 650 x 500 mm)

CARATTERISTICHE PRODOTTO LAVORABILE | PRODUCT FEATURES

Dimensioni min. scatole Min box dimension	L 200 x W 150 x H 120 mm
Dimensioni max. scatole Max box dimension	L 600 x W 500 x H 480 mm
Tipologia di scatole Box type	Scatole di tipo americano American type boxes

RULLIERE | **ROLLER CONVEYOR**



Le rulliere possono essere a rulli cilindrici o conici, folli, motorizzati o frizionati e, grazie alla loro semplicità d'utilizzo ed affidabilità, rappresentano la soluzione più indicata e funzionale per la movimentazione su piano orizzontale, a bassa e media velocità, di scatole, pallet, fusti e più in generale di tutta una serie di prodotti, anche notevolmente pesanti, con superficie di appoggio regolare.



The roller conveyors can have cylindrical or tapered rollers, idle, motorized or clutched ones. They are very easy to use and represent the most functional solution for the horizontal handling, at low and medium speed of boxes, pallets, drums and many other heavy products with regular surface.



RULLIERA FOLLE | **ROLLER CONVEYOR**



RULLIERA FOLLE | **ROLLER CONVEYOR**



RULLIERA FOLLE A ROTELLE | **ROLLER CONVEYOR WITH WHEELS**



NASTRO TRASPORTATORE | **BELT CONVEYOR**



RULLIERA MOTORIZZATA | **POWER ROLLER CONVEYOR**



RULLIERA MOTORIZZATA | **POWER ROLLER CONVEYOR**



CURVA FOLLE A ROTELLE | **CURVED CONVEYOR WITH WHEELS**



CURVA FOLLE A RULLI A 90° | **CURVED CONVEYOR AT 90°**



RULLIERA ESTENSIBILE | **FLEXIBLE ROLLER CONVEYOR WITH WHEELS**



MODULO CADENZATORE | **BLOCKING AND SEPARATING DEVICE**



DEVIATORE A 90° | **LIFTING AND TRASFERRING CONVEYOR**



CADENZATORE CENTRATORE | **CENTER BLOCKING-SEPARATING**



GIRAPACCHI A 90° | **LIFTING AND TURNING AT 90°DEVICE**



CURVA A RULLI MOTORIZZATI | **CURVED POWER ROLLER CONVEYOR**



MODULO SEPARATORE | **SPEED SEPARATING BELT CONVEYOR**

Specifiche tecniche Specification	Rulliera Folle Roller conveyor
Rulli Rollers	Diam.25-32-42-50 mm
Asse Axles	10-12 mm
Distanza interasse Axle pitch	30-60-90-120 mm
Larghezza Width	300-400-500-600
Lunghezza Length	250-500-750-1000- 1500-2000-2500 mm
Altezza Height	450-650 o 650-850 mm
Peso Max Load	50-100 Kg/mt

Specifiche tecniche Specification	Rulliera Folle Roller conveyor
Rulli Rollers	Diam. 25-32-42-50 mm
Asse Axles	10-12 mm
Distanza interasse Axle pitch	30-60-90-120 mm
Larghezza Width	300-400-500-600
Lunghezza Length	250-500-750-1000-1500-2000-2500 mm
Altezza Height	450-650 o 650-850 mm
Peso Max Load	50-100 Kg/mt

Specifiche tecniche Specification	Rulliera Folle a rotelle Roller conveyor with wheels
Rulli Rollers	Diam. 48 mm
Asse Axles	8 mm
Distanza interasse Axle pitch	60-90 mm
Larghezza Width	300-400-500-600 mm
Lunghezza Length	250-500-750-1000- 1500-2000-2500 mm
Altezza Height	450-650 o 650-850 mm
Peso Max Load	50-75 Kg/mt

Specifiche tecniche Specification	Nastro Trasportatore Belt conveyor
Rulli Rollers	Diam. 48-60-93 mm
Asse Axles	-
Distanza interasse Axle pitch	-
Potenza Power	0,12-0,37-0,40 Kw
Velocità Speed	10-15-20-40 mt/min*
Sistema di trasmissione Driving mode	A tappeto With belt
Larghezza Width	100-200-300-400-500- 600-700-800 mm
Lunghezza Length	1000-1500-2000-2500- 3000 mm
Altezza Height	450-500-550-600-650-700-750 mm
Peso Max Load	20-30-40-50 Kg/mt

Specifiche tecniche Specification	Rulliera motorizzata Power roller conveyor
Rulli Rollers	Diam. 32-42-50 mm
Asse Axles	10 mm
Distanza interasse Axle pitch	60-90-120
Potenza Power	0,2-0,40 Kw
Velocità Speed	10 mt/min*
Sistema di trasmissione Driving mode	A cinghiali Small belts
Larghezza Width	300-400-500-600 mm
Lunghezza Length	500-750-1000-1500-2000-2500 mm
Altezza Height	450-650 o 650-850 mm
Peso Max Load	50-75 Kg/mt

Specifiche tecniche Specification	Rulliera motorizzata Power roller conveyor
Rulli Rollers	Diam. 50 mm
Asse Axles	10-12 mm
Distanza interasse Axle pitch	60-90-120
Potenza Power	0,2-0,40 Kw
Velocità Speed	10 mt/min*
Sistema di trasmissione Driving mode	A cinghiali Small belts
Larghezza Width	300-400-500-600 mm
Lunghezza Length	500-750-1000-1500-2000-2500 mm
Altezza Height	450-650 o 650-850 mm
Peso Max Load	50 Kg/mt

Specifiche tecniche Specification	Curva folle a rotelle Curved conveyor with wheels
Rulli Rollers	Diam. 48 mm
Asse Axles	8 mm
Angolo Angle	30-60-90°
Larghezza Width	300-400-500-600 mm
Altezza Height	450-650 o 650-850 mm
Peso Max Load	50 Kg/mt

Specifiche tecniche Specification	Curva folle a rulli Curved conveyor
Rulli Rollers	Diam. 50 mm
Asse Axles	10-12 mm
Angolo Angle	30-60-90°
Larghezza Width	300-400-500-600 mm
Altezza Height	450-650 o 650-850 mm
Peso Max Load	50 Kg/mt

Specifiche tecniche Specification	Rulliera estensibile Flexible conveyor
Rulli Rollers	Diam. 48 mm
Asse Axles	8 mm
Lunghezza Length	1400-4800 mm
Larghezza Width	500 mm
Altezza Height	450-650 o 650-850 mm
Peso Max Load	50 Kg/mt

Specifiche tecniche Specification	Modulo Cadenzatore Blocking and separating
Rulli Rollers	Diam. 50 mm
Asse Axles	Diam. 12 mm
Potenza Power	0,4 Kw
Velocità Speed	15 mt/min *
Sistema di trasmissione Driving mode	Rulli Rollers
Larghezza Width	400-500-600-700-800 mm
Lunghezza Length	1000-1500-2000-2500 mm
Altezza Height	450-500-550-600-650-700-750 mm
Peso Max Load	50 Kg/mt

Specifiche tecniche Specification	Modulo deviatore a 90° Lifting/trasferring conveyor
Rulli Rollers	Diam. 50 mm
Asse Axles	Diam. 12 mm
Potenza Power	0,4 Kw
Velocità Speed	15 mt/min *
Sistema di trasmissione Driving mode	A rulli e Cinghie Rollers/belts
Larghezza Width	400-500-600-700-800 mm
Lunghezza Length	1000-1500-2000-2500 mm
Altezza Height	450-500-550-600-650-700-750 mm
Peso Max Load	50 Kg/mt

Specifiche tecniche Specification	Modulo Cadenzatore Blocking and separating
Rulli Rollers	Diam. 50 mm
Asse Axles	Diam. 12 mm
Potenza Power	0,2 0,4 Kw
Velocità Speed	15 mt/min *
Sistema di trasmissione Driving mode	A catena Chain driving
Larghezza Width	800 mm
Lunghezza Length	1000-1500 mm
Altezza Height	450-650 o 650-850 mm
Peso Max Load	50 Kg/mt

Specifiche tecniche Specification	Modulo Girapacchi a 90° Lifting/turning a 90° device
Rulli Rollers	Diam. 50 mm
Asse Axles	Diam. 12 mm
Angolo rotazione Rotation angle	90°
Potenza Power	0,4 Kw
Velocità Speed	15 mt/min *
Sistema di trasmissione Driving mode	A cinghiali Multi wedge belt coupled driving
Larghezza Width	600-700-800-900-1000 mm
Lunghezza Length	1000-1500 mm
Altezza Height	500-550-650-750 mm
Peso Max Load	50 Kg/mt

Specifiche tecniche Specification	Curva a rulli motorizzati Curved power roller conveyor
Rulli Rollers	Diam. 93 mm
Asse Axles	Diam. 12 mm
Angolo rotazione Rotation angle	45°-60°-90°-180° mm
Potenza Power	0,4 Kw
Velocità Speed	15 mt/min *
Sistema di trasmissione Driving mode	A cinghiali Multi wedge belt coupled driving
Larghezza Width	400-500-600-700-800 mm
Lunghezza Length	-
Altezza Height	400-500-600-650-750 mm
Peso Max Load	100 Kg/mt

Specifiche tecniche Specification	Modulo separatore Speed separating belt conveyor
Rulli Rollers	Diam. 93 mm
Asse Axles	-
Angolo rotazione Rotation angle	-
Potenza Power	0,4 Kw
Velocità Speed	20 mt/min *
Sistema di trasmissione Driving mode	Cinghie e tappeti Multi wedge belt coupled driving
Larghezza Width	580-680-780 mm
Lunghezza Length	1380-1730 mm
Altezza Height	450-500-550-650-750 mm
Peso Max Load	50 Kg/mt

ISG>PACK
AUTOMATIC PACKAGING SYSTEM

🌐 www.isg-pack.com @ info@imballaggiservice.com

Via Castelli Romani Km. 11,700 | Angolo Via Sassuolo, 6
00071 Pomezia | Roma | Italy
T. +39.06.9160.7561 | F. +39.06.9162.5014

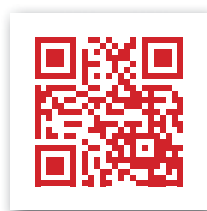

VISITA IL SITO WEB

